

TN Series



Operating and Maintenance Instructions For TN Series Hydraulic Nut Splitters



1025 Conroy Place, Easton PA 18040
Phone: 610-250-5800 * Fax: 610-250-2700
Toll-Free: 1-888-TORCUP-1

E-mail: sales@torcup.com * Website: www.torcup.com

Contents

	Page
Introduction	1
Safety Tips	1
Power Requirements	2
Parts List –Type 1	3
Parts List – Type 2	4
Assembly	5-6
Operation	7
Maintenance	8
Trouble Shooting Table	8
Common Questions	9
Auto Splitter Models Table	10

FIGURE INDEX

	Page
Fig.1 Safe nut cutting	1
Fig.2 Type 1- Exploded view	3
Fig.3 Type 2- Exploded view	4
Fig.4 Type 1- Exploded view	5
Fig.5 Type 2- Exploded view	6
Fig.6 Housing Position – Top view	7
Fig.7 Housing Position – Front view	7
Fig.8 Optional Splitter Position	9
Fig.9 TN Series Nut Splitter	10
Fig.10 Angle headed Splitter Diagram	10

Introduction :

You have chosen the high quality **TN Series NUT SPLITTER** from TorcUP. Now you can cut through the biggest, hardest nuts in seconds. Some of the many benefits of the **TN Series NUT SPLITTER** are:

- Versatility; it can be used on a wide range of nut sizes.
- Flexibility; it fits into tight spaces and cuts virtually any shape nut.
- Precision; the cutting chisel can be calibrated so that only the nut is cut, with no damage to the bolt or stud threads.(with the help of chisel holders for various size A/F nuts)
- Speed; from tool-box to use in less than five minutes and only 20-30 seconds to cut a nut.
- Safety; no hammers, no impact, no sparks or flame, no hot permits required, and no flying fragments.
- Made from the finest steel, heat treated and tempered housing. Chisels manufactured to give you several dozens of splits. Designed to last for a long time.
It's value for money.
Enjoy the experience.
You have made the right choice.

SAFETY TIPS:

- Always wear the appropriate protective equipment, such as safety glasses and gloves.
- Do not allow the hydraulic hoses to kink, twist, curl or bend so tightly that the oil flow within is blocked or reduced.
- Never attempt to grasp a pressurized hose that is leaking.
- Never exceed 10,000 psi of hydraulic pressure while operating a **TN NUT SPLITTER**.
- Never place any body part between the tool and the equipment being worked on, especially moving parts such as the chisel.
- Do not split nuts into sections smaller than half of the nut. Smaller pieces may fly off the nut if it is split in small sections. See fig. 1.

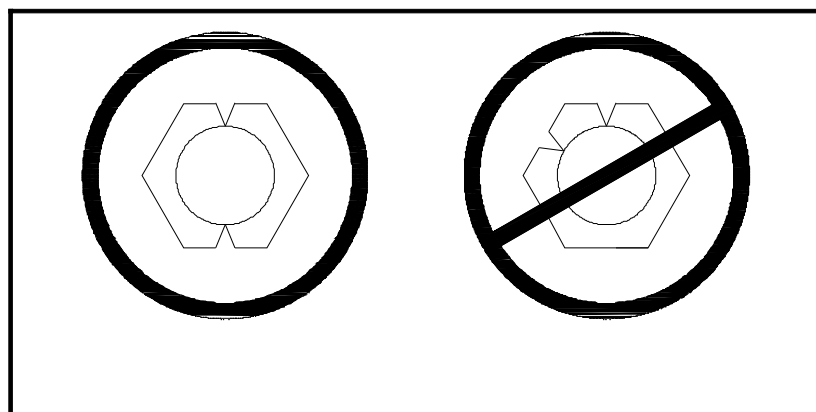

Correct

Wrong

FIG .1

POWER REQUIREMENTS:

The **TN NUT SPLITTER** is hydraulically driven. All models require a hydraulic pump that delivers 10,000 psi of pressure. Any type of hydraulic pump may be used; including air, electric, and hand driven pumps.

Hydraulic pumps that may be used with the TN NUT SPLITTER:

TN Series NUT SPLITTER Model	Pump Model	Power Type
TN-100 - TN505	HP100	Manual-Hand
TN-100 - TN-505	AP100	Air
TN-100 - TN-505	EP100	Electric

All hydraulic pumps include the necessary fittings and hoses.

If a hydraulic pump is not being used to power the **TN NUT SPLITTER**, the following requirements must be met:

TN NUT SPLITTER Model	Valve Type	Hose Rated At:	Usable Minimum Capacity
TN-100	2-Way	10,000 psi	5 Cu ins
TN-105 - TN-200	2-Way	10,000 psi	10 Cu ins
TN-205 - TN-210	2-Way	10,000 psi	44 Cu ins
TN-310 - TN-315	2-Way	10,000 psi	82 Cu ins
TN-405 - TN-505	4-Way	10,000 psi	460 Cu ins

PARTS LIST:

TYPE 1

TN Series NUT SPLITTER with externally threaded chisel holders; used in nut splitters with internal threads in the piston rod.

Item	Description	TN-100	TN-105	TN-200	TN-205	TN-210	TN-310	TN-315
1	Housing	D88045	C87112	C87114	D880055	D88005	D87079	B92035
2	Set Screw	SSN4-20	SSN4-20	SSN4-20	SSB6-16	SSB6-16	SSB6-17	SSB6-17
3	Allen Wrench	WSS2	WSS2	WSS2	WSS3	WSS3	WSS5	WSS5
4	Cutting Chisel	B88046	B86216*	B86216*	B87090	B87090*	B870902*	A92036
5	Chisel Holder	A92016	A92017	A92018	A91006	A91007	A91001	A92037
6	Set Screw for Chisel Holder	SSN4-20	SSN4-20	SSN4-20	SSN4-20	SSN4-20	SSN4-30	SSN4-30
7	Allen Wrench for Chisel Holder	WSS2	WSS2	WSS2	WSS2	WSS2	WSS3	WSS3
8	Hydraulic Cylinder	CRM-10/25	CRM-25/25	CRM-25/25	CRM-50/50	CRM-50/50	CRM-100/50	CRM-100/50
9	Quick Disconnect Female Coupler	GR6-F	GR6-F	GR6-F	GR6-F	GR6-F	GR6-F	GR6-F
10	Handle for Housing (2)	NA			A92030	A92030	A92040	A92040
11	Hex nut for Handle (2)	NA			A92031	A92031	A92041	A92041
11	Tool Box	10TB	25TB	25TB	50TB	50TB	100TB	100TB
12	Eye bolt	NA					3814EB	3814EB

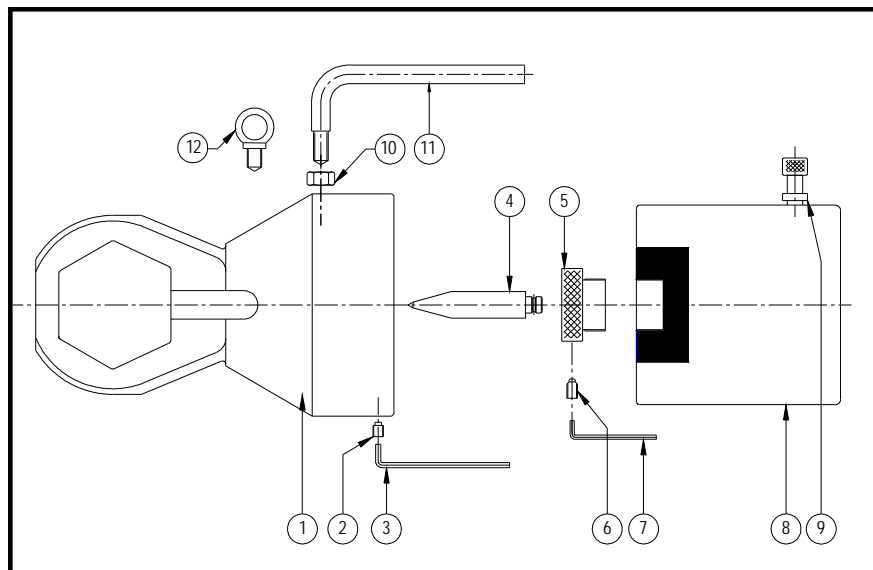

FIG.2

PARTS LIST:

TYPE 2

TN NUT SPLITTER that have a cylinder with threaded bolt holes in the piston rod and chisel holders that use socket head cap screws.

Item	Description	TN-405	TN-500	TN-505
1	Housing	A91002	C87112	C87114
2	Set Screw	SSB6-18	SSB6-18	SSB6-18
3	Allen Wrench	WSS6	WSS6	WSS6
4	Chisel	A91003*	A92015	A92015
5	Chisel Holder	A91004	A91005	A91005
6	Spacers Set	A91005	A92016	A92021
7	Set screw for chisel holder	SSN4-30	SSN4-30	SSN4-30
8	Allen Wrench for Chisel Holder	WSS3	WSS3	WSS3
9	Hydraulic Cylinder	CRM-140/100	CRM-140/100	CRM-140/100
10	Quick Disconnect Female Coupler	GR6-F	GR6-F	GR6-F
11	Allen wrench for cap screws	WSS6	WSS6	WSS6
12	Socket head cap screws (2 each)	SHCS6-12	SHCS6-12	SHCS6-12
		SHCS6-20	SHCS6-20	SHCS6-20
13	Handle for Housing (2)	A92050	A92050	A92050
14	Hex nut for Handle (2)	A902051	A902051	A902051
15	Eye bolt	456EB	456EB	456EB
16	Tool box	150TB	150TB	150TB

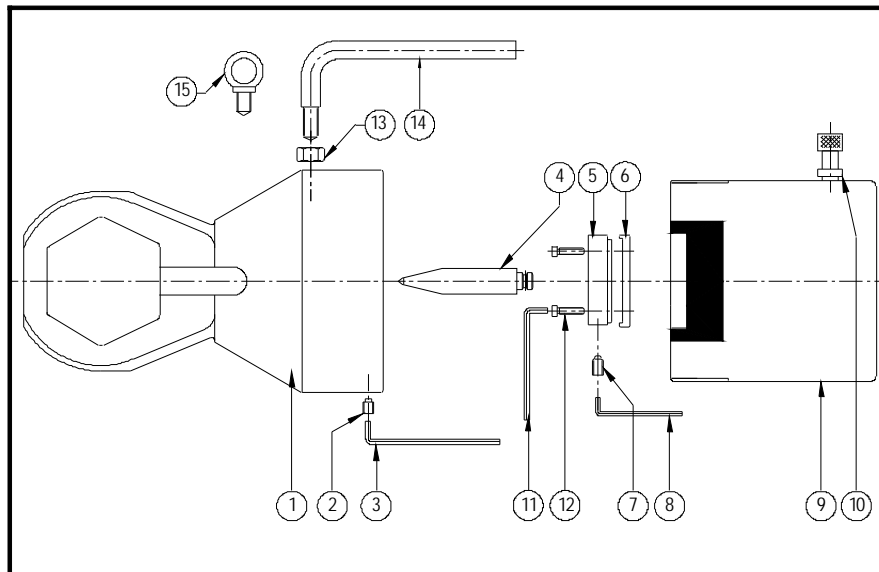

FIG.3

ASSEMBLY:

There are two types of Auto-Splitter nut splitters. The only design difference between the two is the chisel holder. (See table below)

The assembly directions are separated into two sections:

Section 1 applies only to type 1 splitters, Section 2 applies to type 2 splitters only. Refer to the table below to find which type of **TN NUT SPLITTER** assembly directions to follow.

TYPE 1	TYPE 2
TN-100	TN-405
TN-105	TN-500
TN-205	TN-505
TN-210	
TN-310	
TN-315	

SECTION 1 - ASSEMBLY DIRECTIONS

Type 1

Type 1- **TN NUT SPLITTERS** with externally threaded chisel holders; used in nut splitters with internal threads in the piston rod.

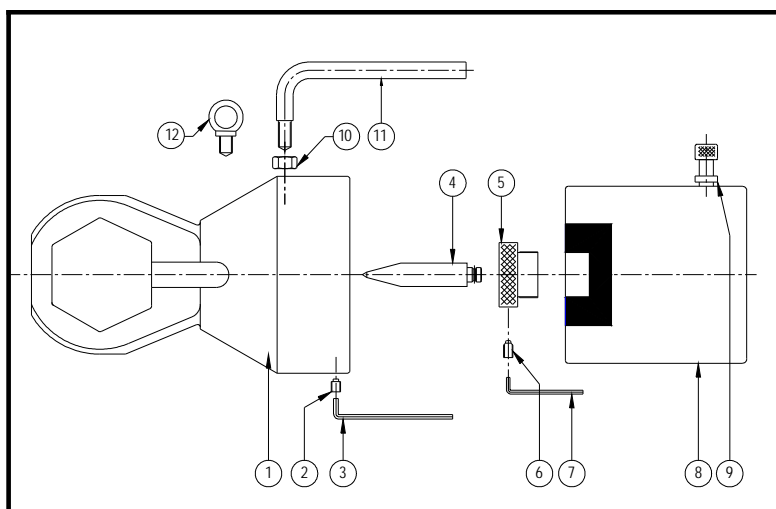

FIG.4

1. Unscrew the chisel holder (5) from cylinder (8).
2. Place the cutting chisel (4) in the drilled hole in the chisel holder (5). Insert the set screw (7) into the side of the chisel holder and tighten using the provided Allen Wrench (7).

Note: Do not overtighten the set screw. The chisel should be free to turn.

Each **TN NUT SPLITTER** is designed to cut a wide range of sizes. This is achieved by using calibration chisel holder. For example, to cut a 1 7/8" nut (TN-200 or TN-205) simply insert the holder marked 1-7/8".

3. Screw in the chisel holder (5) until it is seated metal to metal.
Warning: Thread chisel holder completely. Failure to do so will result in severe damage to the cylinder rod and chisel holder.
4. Connect the quick disconnect (9) to a hydraulic pump using a 10,000 psi hydraulic hose. Refer to Power Requirements on page 3 for appropriate hose and pump.
6. Extend cylinder rod; HOLD in the extended position.
5. Place the housing (1) on the hydraulic cylinder (9). The chisel (4) will project into the housing.
6. Completely thread the housing onto the cylinder while the chisel is extended. Lock in place by inserting the set screw on the side of the housing and tighten with the Allen Wrench.
7. Retract the cylinder rod - the chisel will retract.
8. Proceed to the Operation Section of this manual.

SECTION 2 -ASSEMBLY DIRECTIONS:

TYPE 2

Type 2 **TN NUT SPLITTERS** that have a cylinder with threaded bolt holes in the piston rod and chisel holders that use socket head cap screws.

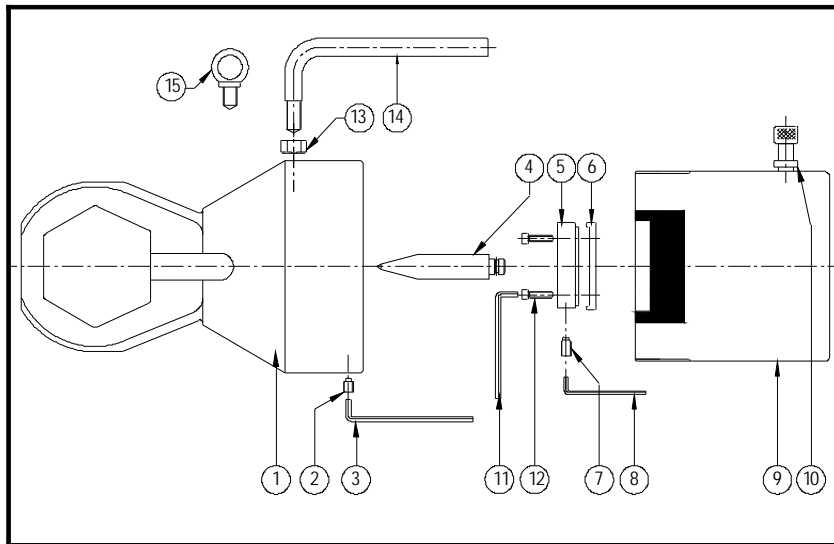

FIG.5

1. Remove the two socket head cap screws (12) from the cylinder (9) using the Allen Wrench (11).
2. Place the cutting chisel (4) into the center-drilled hole in the chisel holder (5). Insert the set screw (7) into the side of the chisel holder and tighten using the provided Allen Wrench (8).
3. Line up the holes of the spacer (6) (when needed) and the chisel holder (5) with the bolt holes in the cylinder (9). Use the socket head cap screws (12)* to bolt both the spacer and chisel holder onto the cylinder.

*Some splitter models are equipped with two lengths of cap screw to accommodate spacer thickness. The cap screws should be long enough to fasten the spacer and chisel holder to the cylinder. Make sure that the cap screws are not too long. If the longer screws are used without spacers, the chisel holder will not be held tightly in place.

Note Each **TN NUT SPLITTER** is designed to cut a wide range of sizes. This is achieved by using calibration spacers.

For example, to cut a 4.1/8" nut (TN-405 or TN-500) simply insert the spacer marked 4.1/8". No other spacer is needed. The largest nut size in the range of each nut splitter does not require a spacer.

4. Connect the quick disconnect (10) to a hydraulic pump using a 10,000 psi hydraulic hose. Refer to Power Requirements on page 3 for appropriate hose and pump.
5. Extend cylinder rod; HOLD in the extended position.
6. Place the housing (1) on the hydraulic cylinder (9). The chisel (4) will project into housing. Completely thread the housing onto the cylinder while the chisel is extended. Lock in place by inserting the set screw (2) on the side of the housing and tightening with the Allen Wrench (3).
7. Retract the cylinder rod - the chisel will retract.
8. Proceed to the Operation Section of this manual.

OPERATION:

Note: Read and follow the assembly instructions and safety tips before operating the **TN NUT SPLITTER**.

1. Lubricate the tip of the chisel with anti-seize lubricant before each cut.
2. Place the internal hex of the housing over the nut. Pull the housing against the back side of the nut, with the nut centered on the back side of the internal hex. The housing of the nut splitter should be flat on the surface of the flange. The cutting chisel should be as close to the bottom of the nut as possible and be centered on a flat of the nut. See **figure 6**.

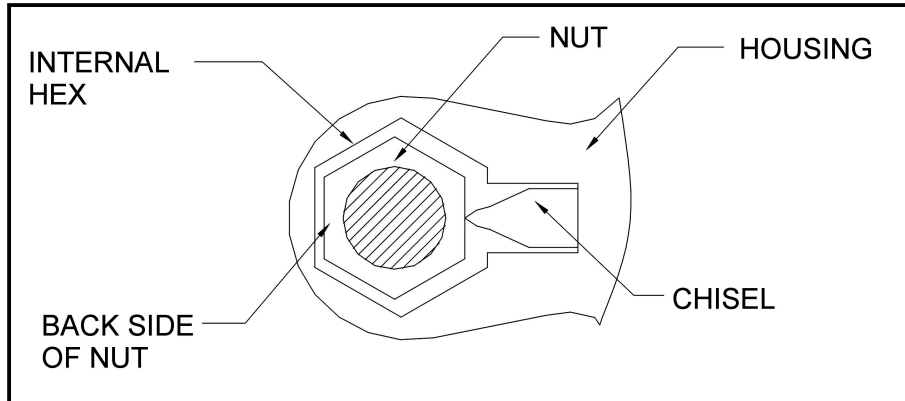

FIG.6

3. Extend the chisel slowly until it makes contact with the nut face. Check that the chisel is resting squarely on the center of a nut flat. See FIG. 7

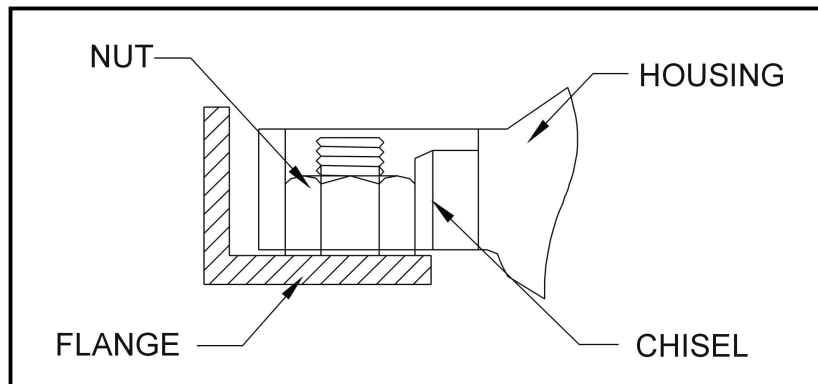

FIG.7

4. Continue to apply hydraulic pressure to the cylinder until the nut is severed. A loud pop will occur, signifying that the nut is split.

Note For complete nut removal, it may be necessary to cut the opposite face of the nut so that it falls away from the stud. If a second cut is required, proceed with the following steps:

5. Rotate the nut 180 degrees, after the first face has been split. An oversized wrench or hammer may be required to turn the nut.
6. Split the second face. Return to step 1 and follow the same procedure.

MAINTENANCE:

The **TN NUT SPLITTER** is designed to be a low maintenance tool. The following should be done on a regular basis to increase the longevity of the tool:

- √ Always lubricate the chisel point with anti-seize lubricant before each cut.
- √ Do not let the chisel get dull. Resharpener the chisel with a hand whetstone or slowly with a grinder. Be sure to keep the chisel wet while sharpening.
- √ Replace the dust covers on the quick disconnects and thread protectors on the cylinder after each use.
- √ Store the **TN NUT SPLITTER** in its custom-made tool- box or case.

TROUBLE SHOOTING TABLE:

Problem	Possible Causes:	Possible Solutions
Cylinder does not hold pressure	<ol style="list-style-type: none">1. Cylinder seal leaking2. Leaking connection3. Pump malfunction	<ol style="list-style-type: none">1. Change cylinder2. Tighten connections3. Change pump
Cylinder does not hold advance or advances partially	<ol style="list-style-type: none">1. Pump release valve open2. Not enough oil in pump3. Air in system4. Couplers not tightened5. Pump reservoir too small	<ol style="list-style-type: none">1. Close valve2. Add oil3. Bleed air4. Fully tighten couplers5. Change pump (use one with a larger reservoir)
Cylinder advances slowly	<ol style="list-style-type: none">1. Leaking connection2. Restricted hydraulic hose or fitting3. Loose coupler4. Pump flow rate too slow	<ol style="list-style-type: none">1. Tighten connections2. Change hoses or3. Tighten couplers4. Change pump (use one with a faster flow rate)
Cylinder does not retract, retracts Slowly or retracts partially	<ol style="list-style-type: none">1. Pump release valve closed2. Coupler not fully closed3. Blocked hydraulic hose4. Damage retraction spring in cylinder5. Pump reservoir overfilled	<ol style="list-style-type: none">1. Open valve2. Close coupler3. Replace hoses4. Replace spring5. Remove excess oil
Chisel does not penetrate nut	<ol style="list-style-type: none">1. Inadequate pump pressure2. Using incorrect spacer or chisel holder.3. Chisel edge blunt4. Housing not fully threaded	<ol style="list-style-type: none">1. Increase to 10,000 psi2. Change spacer or chisel holder3. Sharpen or replace chisel4. Thread housing all the way
Chisel cuts through nut and damages the stud	<ol style="list-style-type: none">1. Using incorrect spacer or chisel holder	<ol style="list-style-type: none">1. Check holder or spacer size, change chisel holder or spacer

COMMON QUESTIONS:

How many cuts will the chisel make?

Answer: Dozens of cuts have been achieved before sharpening with proper maintenance and operation. It is recommended to have two chisels on every job to be used alternately without letting any one chisel get too dull.

Can I sharpen the chisel?

Answer: Yes, but ensure the chisel stays cool while sharpening. Refer to the Maintenance Section for further instructions.

Must I always have 10,000 psi capability?

Answer: Yes, regardless of the nut splitter model or the nut size.

How do I know what size power unit to use?

Answer: All nut splitter models require 10,000 psi. Please refer to the Power Requirements Section on page 3 for pump specifications.

My nut splitter is not cutting. Why?

Answer: Make sure you have 10,000 psi; check couplers for tight connections; refer to the trouble shooting guide.

I have reached maximum output pressure and the nut I am attempting to split is still not cut. What do I do?

Answer: Lubricate the cutting chisel again. Reposition the nut splitter, over the nut, upside down. This will place the chisel approximately 1/4" to 1/2" above the surface of the Range. Make sure the cutting chisel is positioned in the same location where the previous cut was attempted. There will be 1/4" to 1/2" of the chisel visible above the nut. Apply hydraulic pressure until the nut is severed. See figure 8.

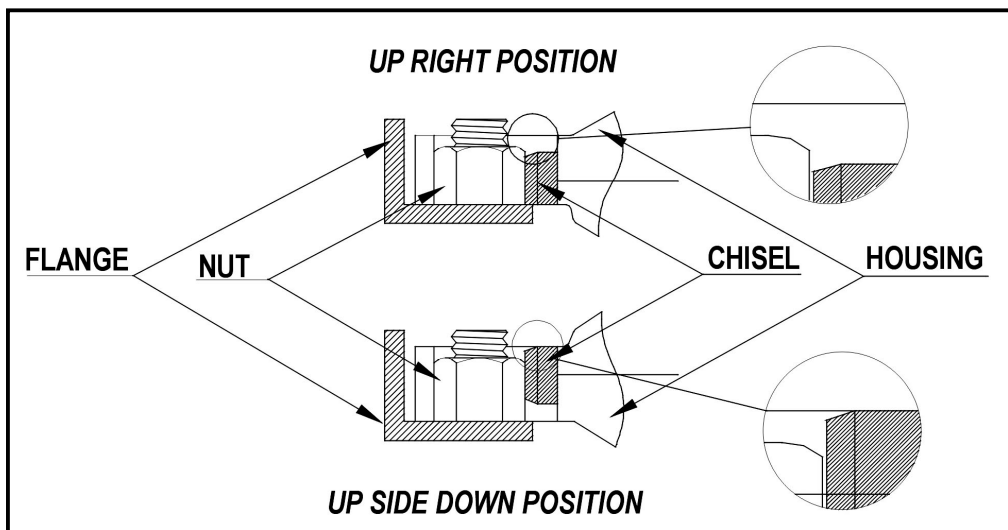

FIG.8

How can I be sure not to cause sparks?

Answer: Use steam or spray water on cutting chisel during use.

The chisel seems slow. How do I increase the speed?

Answer: Change to a different pump unit with a faster flow rate.

TN Series NUT SPLITTER MODELS:

Choose the right TN NUT SPLITTER for your needs

TN Series NUT SPLITTER Dimensions See figure 9 and 10

Model	Stud Diameter	Nut A/F	A	B	C	D	E	F	Weight
TN-100 Anglehead	7/16-5/8" 11-16 mm	1/2"-1" 13-24 mm	11/16" 17.5 mm	10.1/4" 260 mm	30°	1/4" 6 mm	1-1/16" 27 mm	2-7/8" 72.5 mm	8.1 lbs. 3.8 kg
TN-105	7/16"-7/8" 11-22 mm	5/8"-1-7/16" 16-36 mm	1-1/2" 38.1mm	10.7/16" 271 mm	60°	3/8" 9.5 mm	1-1/2" 38.1 mm	4.1/8" 105 mm	21.5lbs. 9.8 kg
TN-200	7/8"-1-1/4" 22-32 mm	1-7/16"-2" 36-51 mm	1-1/2" 38.10 mm	11.5/16" 287 mm	60°	1/2" 12.7 mm	2-1/8" 54 mm	4.1/4" 108 mm	23 lbs. 10.4 kg
TN-205	1-1/4"-1-1/2" 32-38 mm	1-13/16"-2-3/8" 46-60 mm	2-1/4" 57.1 mm	15.5/32" 385 mm	60°	9/16" 14.3 mm	2-1/2" 63.5 mm	6.7/16" 164 mm	72 lbs. 32.5 kg
TN-210	1-3/8"-1-3/4" 34-45 mm	2-1/4"-2-3/4" 57-70 mm	2-1/4" 57.1 mm	15.11/16" 398 mm	60°	11/16" 17.5 mm	2-7/8" 73 mm	6.7/16" 164 mm	72 lbs. 32.9 kg
TN-310	1-3/4"-2-1/4" 45-57 mm	2-3/4"-3-1/2" 70-89 mm	3-1/16" 77.8 mm	18.1/8" 460 mm	60°	3/4" 19 mm	3-7/8" 98.4 mm	8.7/16" 214 mm	159 lbs. 72.1 kg
TN-315	2"-2-1/2" 50-64 mm	3-1/8"-3-7/8" 79-98 mm	3-1/8" 79.4 mm	19.7/32" 488 mm	60°	7/8" 22.2 mm	4-1/4" 108 mm	8.7/16" 214 mm	164 lbs. 74.5 kg
TN-405	2-1/2"-2-3/4" 64-70 mm	3-3/4"-4-1/4" 95-108 mm	3-3/4" 95.3 mm	22.13/16" 579mm	60°	1-1/8" 28.6 mm	4-5/8" 117.5 mm	9-7/8" 250 mm	252 lbs. 114.2 kg
TN-500	3"-3-1/4" 76-83 mm	4-1/2"-5" 114-127 mm	4-1/8" 104.8 mm	23.7/32" 590 mm	60°	1-1/8" 28.6 mm	5-3/8" 136.5 mm	9-7/8" 250 mm	257 lbs. 116.62kg
TN-505	3-1/4"-3-1/2" 83-89 mm	4-7/8"-5-3/8" 124-136 mm	4-1/8" 104.8 mm	23.17/32" 598 mm	60°	1-1/8" 28.6 mm	5-7/8" 149.2 mm	9-7/8" 250 mm	263 lbs. 119.5 kg

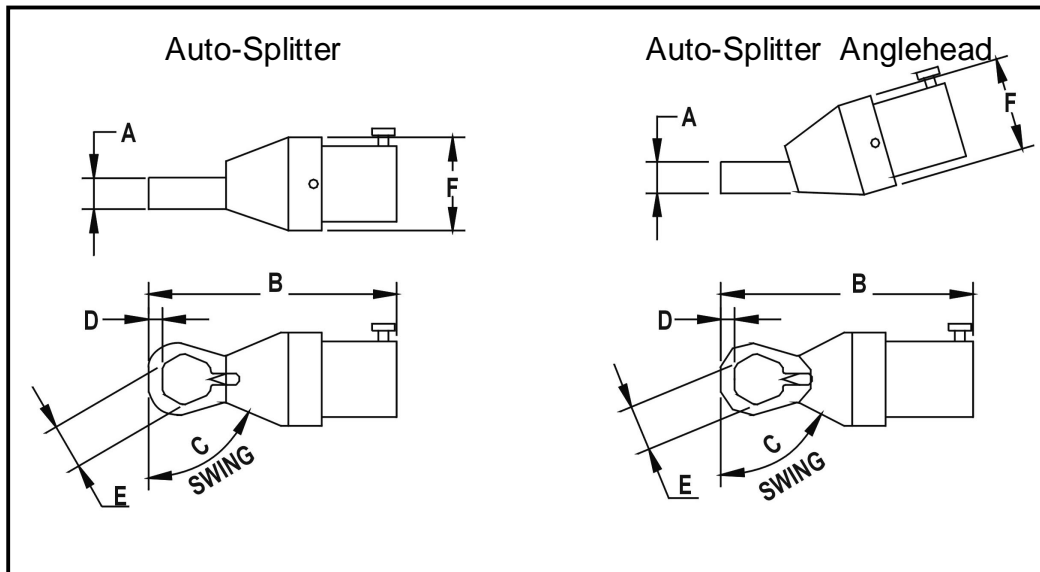

Figure 9

Figure 10

Limited Warranty

All products are warranted against defects of material or workmanship for period of 12 MONTHS from the date shipped when these products are used within the service, specification and pressure range for which they were manufactured. Under no circumstances will the company assume responsibility for equipment defects not of our manufacture. This warranty is limited to replacement without charge, of parts found to be defective in material or workmanship and does not extend to claims for labor, expense, or other loss or damage occasioned by such defect of material or workmanship. No unauthorized back charges will be accepted. This warranty does not cover deterioration by corrosion, erosion, or any cause of failure other than defect of material or workmanship. Purchasers are expected to determine the suitability of these products of their particular purposes. This warranty is in place and in lieu of all warranties of merchantability and fitness. No other warranty, expressed or implied will be allowed without the written agreement. Any adjustments to this warranty must first be approve in writing.