



OPERATION AND MAINTENANCE MANUAL FOR TorcUP T U-2, TU-3, TU-7, TU-11, TU-27 AND TU-60 SQUARE DRIVE HYDRAULIC TORQUE WRENCHES

NOTICE

Series TU-2, TU-3, TU-7, TU-11, TU-27 and TU-60 Square Drive Hydraulic Torque Wrenches are designed for installing and removing threaded fasteners requiring precise high torque during bolt makeup and maximum torque during bolt breakout.

TorcUP Inc. is not responsible for customer modification of tools for applications on which TorcUP Inc. was not consulted.

WARNING

**IMPORTANT SAFETY INFORMATION ENCLOSED.
READ THIS MANUAL BEFORE OPERATING TOOL.
IT IS THE RESPONSIBILITY OF THE EMPLOYER TO PLACE THE INFORMATION IN THIS
MANUAL INTO THE HANDS OF THE OPERATOR.
FAILURE TO OBSERVE THE FOLLOWING WARNINGS COULD RESULT IN INJURY.**

PLACING TOOL IN SERVICE

- Always operate, inspect and maintain this tool in accordance with American National Standards Safety Code for Hydraulic Rams and Jacks (ANSI B30.1)
- This tool will function using an air or electric powered hydraulic pump. Adhere to the pump safety requirements and follow instructions when connecting the pump to the tool.
- Use only equipment rated for the same pressure and torque.
- Use only a hydraulic pump capable of generating 10,000 psig (681 bar) maximum pressure with this tool.
- Use only twin line hydraulic hose rated for 10,000 psig (681 bar) pressure with this tool.
- Do not interchange the male and female swivel inlets on the tool or the connections on one end of the hose. Reversing the inlets will reverse the power stroke cycle and may damage the tool.
- Do not use damaged, frayed or deteriorated hoses and fittings. Make certain there are no cracks, splits or leaks in the hoses.

- Use the quick connect system to attach the hoses to the tool and pump. Make certain the spring-loaded retaining rings are fully engaged and the safety rings are tightly threaded against the spring-loaded retaining rings to prevent the connectors from disengaging under pressure.
- When connecting hoses that have not been preloaded with hydraulic oil, make certain the pump reservoir is not drained of oil during start-up.
- Do not remove any labels. Replace any damaged label.

USING THE TOOL

- Do not handle pressurized hoses. Escaping oil under pressure can penetrate the skin, causing serious injury. If oil is injected under the skin, see a doctor immediately.
- Never pressurize uncoupled couplers. Only use hydraulic equipment in a coupled system.
- Always wear eye protection when operating or performing maintenance on this tool.
- Always wear head and hand protection and protective clothing when operating this tool.

NOTICE

The use of other than genuine TorcUP replacement parts may result in safety hazards, decreased tool performance, and increased maintenance, and may invalidate all warranties.

Repairs should be made only by authorized personnel. Consult your nearest TorcUP Authorized Servicenter. Refer All Communications to the Nearest TorcUP Office or Distributor.

TorcUP Inc. 2000
Printed in U.S.A.

**For Technical Support and Information Contact:
TorcUP, Inc.
1025 Conroy Place, Easton, PA 18040
Toll Free: (888) TORCUP-1 Fax: (610) 250-2700
E-mail: info@torcup.com**

WARNING

FAILURE TO OBSERVE THE FOLLOWING WARNINGS COULD RESULT IN INJURY

USING THE TOOL

- Keep hands, loose clothing and long hair away from the reaction arm and working area during operation. Do not attempt to support the tool with your hands during operation.
- This tool will exert a strong reaction force. Use proper mechanical support and correct reaction arm positioning to control these forces. Do not position the reaction arm so that it tilts the tool off the axis of the bolt and never use the swivel inlets as a reaction stop.
- Avoid sharp bends and kinks that will cause severe back-up pressure in hoses and lead to premature hose failure.

- Use accessories recommended by TorcUP.
- Use only impact sockets and accessories. Do not use hand (chrome) sockets or accessories.
- Use only sockets and accessories that correctly fit the bolt or nut and function without tilting the tool off the axis of the bolt.
- This tool is not designed for working in explosive atmospheres
- This tool is not insulated against electric shock. When using this tool with a pump having an electrical power source or circuits, follow the pump instructions for proper grounding.

Always wear eye protection when operating or performing maintenance on this tool.



Always wear ear protection when operating this tool.



Always turn off the pump and disconnect the power before installing, removing, or adjusting any accessory on this tool, or before performing any maintenance on this tool.



The Torque Reaction Arm must be positioned against a positive stop. Do not use the Arm as a dead handle. Take all precautions to make certain the operator's hand cannot be pinched between the Arm and a solid object.

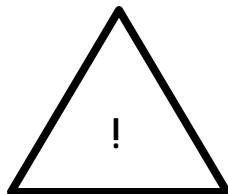

Operate at 10,000 psig (681bar) maximum pressure.

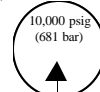

Keep body stance balanced and firm. Do not overreach when operating this tool.



Do not carry the tool by the hose.



Do not use damaged, frayed or deteriorated hydraulic hoses and fittings.



PLACING THE TOOL IN SERVICE

CONNECTING THE TOOL

1. Attach the twin line hose to the swivel inlets of the Square Drive Torque Wrench using the spring-loaded quick connect ends. After making certain that they are fully engaged, thread the safety rings tightly against the spring-loaded retainer rings.
2. Connect the opposite ends of the hose to the Pump in the same manner.

Drive into the Housing until the Drive projects out the opposite side of the tool. For **Model TU-27 and TU-60**, loosen and remove the Square Drive Retaining Screw and pull the Square Drive out of the Housing. Insert the Square Drive into the opposite side of the Housing and secure it by installing the Screw in the splined end of the Drive.

ADJUSTMENTS

SETTING THE SQUARE DRIVE FOR ROTATION

The position of the Square Drive when looking toward the Shroud will determine if the tool is set to tighten or loosen the nut. When the Square Drive extends to the left when looking at the Shroud with the inlets away from you, the tool is set to loosen the nut. When the Square Drive extends to the right, the tool is set to tighten the nut. To change the direction of rotation for **Models TU-2, TU-3, TU-7 and TU-11** simply push the Square

SETTING THE TORQUE

After determining the desired torque, use the torque conversion chart on the Shroud or the torque conversion charts on page 5 to determine the pressure that is necessary to achieve that torque.

1. Connect the tool to the power supply and turn the pump on.
2. Depress the remote control button causing the pressure to be shown on the gauge.
3. Adjust the pressure by loosening the wing nut that locks the pressure adjustment thumbscrew. Rotate the thumbscrew clockwise to increase the pressure and counterclockwise to decrease the pressure. When

PLACING THE TOOL IN SERVICE

decreasing pressure, always lower the pressure below the desired point and then bring the gauge back up to the desired pressure.

4. When the desired pressure is reached, retighten the wing nut and cycle the tool again to confirm that the desired pressure setting has been obtained.

SETTING THE REACTION ARM

The function of a reaction device is to hold the tool in position against the forces generated to tighten or loosen bolts or nuts. Hydraulic wrenches generate tremendous force.

WARNING

An improperly positioned reaction arm may result in operator injury or damaged tooling.

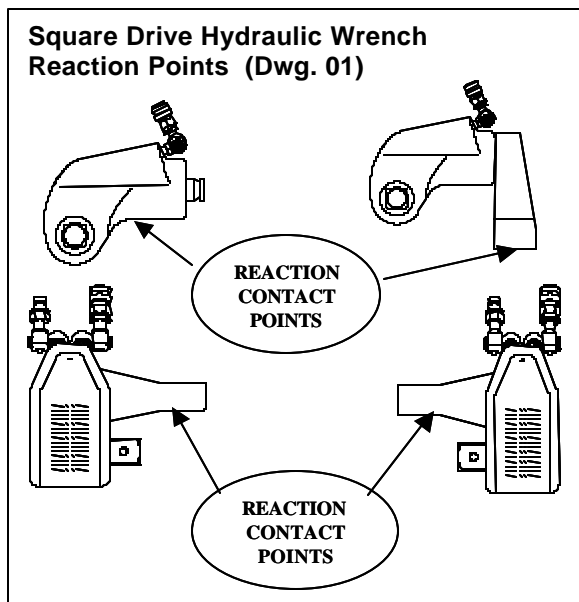

Make sure the Reaction Arm is positioned correctly. (Refer to Drawing 01).

The Reaction Arm can be positioned numerous places within a 360° circle. However, for the Arm to be correctly positioned, it must be set within a 90° quadrant of that circle. That quadrant is the area located between the protruding Square Drive and the bottom of the Housing away from the Swivel Inlets. It will always be toward the lower half of the Housing and on one side of the Housing when tightening and the other side when loosening.

OPERATING THE WRENCH

The position of the Square Drive relative to the Shroud determines whether the action will tighten or loosen the nut. (Refer to Dwg. 02 for application examples).

The power stroke of the Piston Assembly will always turn the Square Drive toward the Shroud.

WRENCH POSITIONS

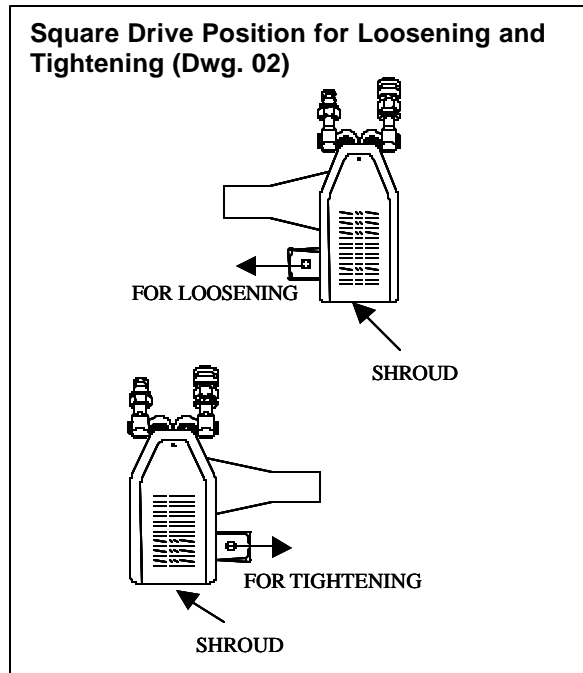

1. Place the Square Driver in the socket and the socket on the nut. Make certain the Square Driver and socket are the correct size for the nut and that the Driver fully engages the socket and the socket fully engages the nut.
2. Position the reaction arm or surface against an adjacent nut, flange or solid system component. Make certain that there is clearance for the hoses, swivels, inlets and End Plug. **DO NOT** allow the tool to react against the hoses, swivels, inlets or End Plug.
3. After having turned the Pump on and presetting the pressure for the correct torque, depress the remote control button to advance the Piston Assembly
4. When the wrench is started, the reaction surface of the wrench or Reaction Arm will move against the contact point and the nut will begin to turn.
5. When the nut is no longer turning and the Pump Gauge reaches the preset pressure, release the remote control button. The piston rod will retract when the button is released and under normal conditions, an audible “click” will be heard as the tool resets itself.
6. Continue to cycle the tool until it “stalls” and the preset psi/torque has been attained.
7. Once the nut stops rotating, cycle the tool one last time to achieve total torque.

PLACING THE TOOL IN SERVICE

LUBRICATION

Mobil 1 ® Synthetic Grease

Lubrication frequency is dependent on factors known only to the user. The amount of contaminants in the work area is one factor. Tools used in a clean room environment will obviously require less service than a tool used out-doors and dropped in loose dirt or sand. Mobil 1 ® Synthetic Grease is formulated not to wash out of the tool in areas where lubrication is critical.

Whenever lubrication is required, lubricate as follows:

1. Remove the Drive Plate, Ratchet, Segment Pawl and Drive Sleeves as instructed in the Maintenance Section and wash the components in a suitable cleaning solution in a well-ventilated area.
2. After drying the components, wipe a film of Mobil 1 ® Synthetic Grease onto the wear surface of both Drive Sleeves and the ends of the Ratchet.
3. Spread a light film of Mobil 1 ® Synthetic Grease onto the inner face and both sides of the Drive Plate.
Do not pack the teeth of the Segment Pawl or Ratchet with lube. It can prevent the teeth from engaging properly.
4. Place a daub of Mobil 1 ® Synthetic Grease in the piston rod recess of the Drive Plate before linking the Piston Rod to the Drive Plate at assembly.

CRITICAL LUBRICATION

It is imperative to lubricate the piston rod recess of the Drive Plate to Piston Rod contact area every 80 hours of continuous duty cycling.

Lubricate as follows:

1. Remove Shroud Screws, Shroud, and Roll Pin.
2. Pry the Drive Plate assembly forward from the Piston Rod to expose the recessed contact area in the Drive Plate.
3. With a rag, wipe clean the area and apply a sizeable amount of Mobil 1 ® Synthetic Grease.
4. Reassemble as instructed in the maintenance section.

TU Series Torque Conversion Chart

P.S.I./FT./lbs							Bar/N.M.						
P.S.I.	TU-2 ft./lbs.	TU-3 ft./lbs.	TU-7 ft./lbs.	TU-11 ft./lbs.	TU-27 ft./lbs.	TU-60 ft./lbs.	Bar	TU-2 N.m.	TU-3 N.m.	TU-7 N.m.	TU-11 N.m.	TU-27 N.m.	TU-60 N.m.
1,000	127	330	740	1,090	2,720	5,943	68	172	447	1,003	1,478	3,687	8,056
1,200	152	395	888	1,308	3,264	7,132	82	206	535	1,204	1,773	4,425	9,668
1,400	178	460	1,036	1,526	3,808	8,320	95	241	624	1,404	2,069	5,162	11,279
1,600	203	525	1,185	1,745	4,352	9,509	109	275	712	1,606	2,366	5,900	12,890
1,800	229	590	1,332	1,962	4,896	10,697	122	310	800	1,806	2,660	6,637	14,501
2,000	255	655	1,470	2,210	5,440	11,662	136	346	888	1,993	2,996	7,374	15,809
2,200	279	722	1,617	2,430	5,984	12,828	150	378	979	2,192	3,294	8,112	17,390
2,400	305	789	1,765	2,652	6,528	13,994	163	413	1,070	2,393	3,595	8,849	18,971
2,600	330	856	1,911	2,873	7,072	15,161	177	447	1,160	2,591	3,895	9,587	20,552
2,800	356	923	2,058	3,095	7,616	16,327	190	483	1,251	2,790	4,196	10,324	22,133
3,000	380	990	2,210	3,340	8,160	17,387	204	515	1,342	2,996	4,528	11,062	23,570
3,200	406	1,058	2,358	3,560	8,704	18,546	218	550	1,434	4,826	4,826	11,799	25,141
3,400	432	1,126	2,505	3,785	9,248	19,705	231	586	1,526	3,395	5,131	12,537	26,712
3,600	457	1,194	2,652	4,005	9,792	20,864	245	620	1,619	3,595	5,429	13,274	28,284
3,800	483	1,262	2,800	4,230	10,336	22,024	258	655	1,711	3,796	5,734	14,011	29,855
4,000	510	1,330	2,960	4,400	10,880	23,286	272	691	1,803	4,013	5,965	14,749	31,567
4,200	533	1,397	3,108	4,620	11,424	24,450	286	723	1,894	4,213	6,263	15,486	33,145
4,400	559	1,464	3,256	4,840	11,968	25,615	299	758	1,985	4,414	6,561	16,224	34,723
4,600	584	1,531	3,405	5,060	12,512	26,779	313	792	2,075	4,616	6,859	16,961	36,301
4,800	609	1,598	3,552	5,280	13,056	27,943	326	826	2,166	4,815	7,158	17,699	37,880
5,000	635	1,665	3,716	5,500	13,600	29,322	340	861	2,257	5,037	7,456	18,436	39,749
5,200	660	1,732	3,865	5,720	14,144	30,495	354	895	2,348	5,239	7,754	19,174	41,339
5,400	686	1,799	4,013	5,940	14,688	31,668	367	930	2,439	5,440	8,052	19,911	42,929
5,600	711	1,856	4,162	6,160	15,232	32,841	381	964	2,516	5,642	8,350	20,648	44,519
5,800	737	1,933	4,311	6,380	15,776	34,014	394	999	2,620	5,843	8,649	21,386	46,109
6,000	760	2,000	4,440	6,620	16,320	34,696	408	1,030	2,711	6,019	8,974	22,123	47,404
6,200	787	2,065	4,588	6,838	16,864	36,135	422	1,067	2,799	6,219	9,270	22,861	48,984
6,400	813	2,130	4,736	7,060	17,408	37,300	435	1,102	2,887	6,420	9,571	23,598	50,564
6,600	838	2,195	4,884	7,280	17,952	38,466	449	1,136	2,976	6,621	9,869	24,336	52,144
6,800	864	2,260	5,032	7,500	18,496	39,632	462	1,171	3,064	6,821	10,167	25,073	53,725
7,000	890	2,325	5,180	7,710	19,040	40,914	476	1,206	3,152	7,022	10,452	25,811	55,463
7,200	914	2,398	5,328	7,927	19,584	42,083	490	1,239	3,251	7,223	10,746	26,548	57,048
7,400	940	2,461	5,476	8,147	20,128	43,252	503	1,274	3,336	7,423	11,044	27,286	58,632
7,600	965	2,529	5,625	8,368	20,672	44,421	517	1,308	3,428	7,625	11,344	28,023	60,217
7,800	991	2,597	5,772	8,588	21,216	45,590	530	1,343	3,520	7,825	11,642	28,760	61,802
8,000	1,015	2,665	5,920	8,820	21,760	46,859	544	1,376	3,613	8,025	11,956	29,498	63,522
8,200	1,041	2,731	6,068	9,045	22,304	48,030	558	1,411	3,702	8,226	12,261	30,235	65,110
8,400	1,067	2,797	6,216	9,265	22,848	49,202	571	1,446	3,792	8,426	12,560	30,973	66,698
8,600	1,092	2,863	6,365	9,485	23,392	50,373	585	1,480	3,881	8,628	12,858	31,710	68,286
8,800	1,118	2,929	6,512	9,705	23,936	51,545	598	1,516	3,971	8,828	13,156	32,448	69,874
9,000	1,145	2,995	6,660	9,930	24,480	52,799	612	1,552	4,060	9,028	13,461	33,185	71,574
9,200	1,168	3,062	6,808	10,148	25,024	53,972	626	1,583	4,151	9,229	13,757	33,923	73,165
9,400	1,194	3,129	6,956	10,368	25,568	55,146	639	1,619	4,242	9,430	14,055	34,660	74,755
9,600	1,219	3,196	7,105	10,588	26,112	56,319	653	1,652	4,332	9,632	14,353	35,397	76,346
9,800	1,245	3,263	7,252	10,810	26,656	57,492	666	1,688	4,423	9,831	14,654	36,135	77,936
10,000	1,270	3,330	7,400	11,010	27,200	59,401	680	1,722	4,514	10,031	14,925	36,872	80,524

TU-2, 3, 7, 11 Series Wrench

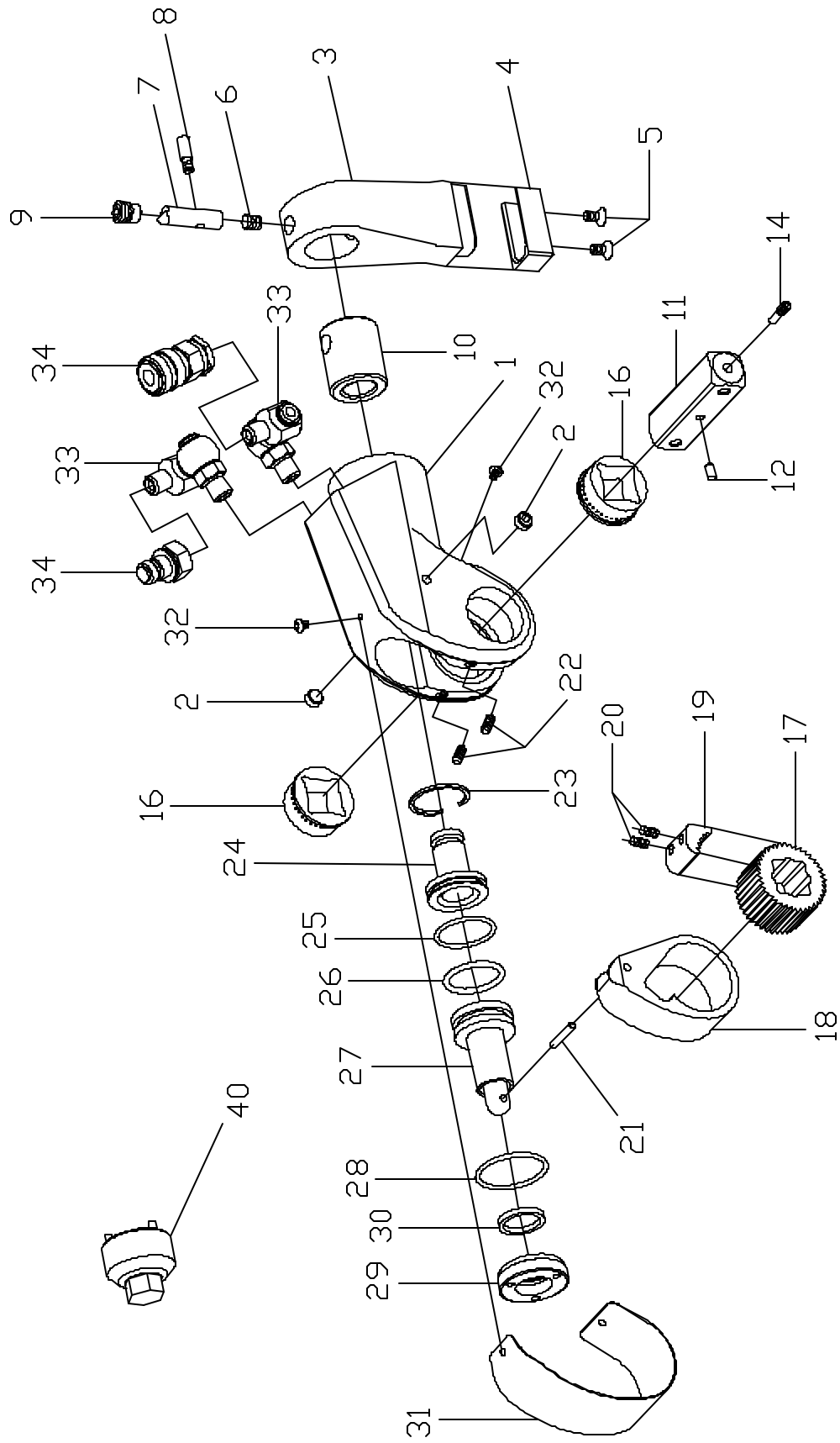

TU – 27 Series Wrench

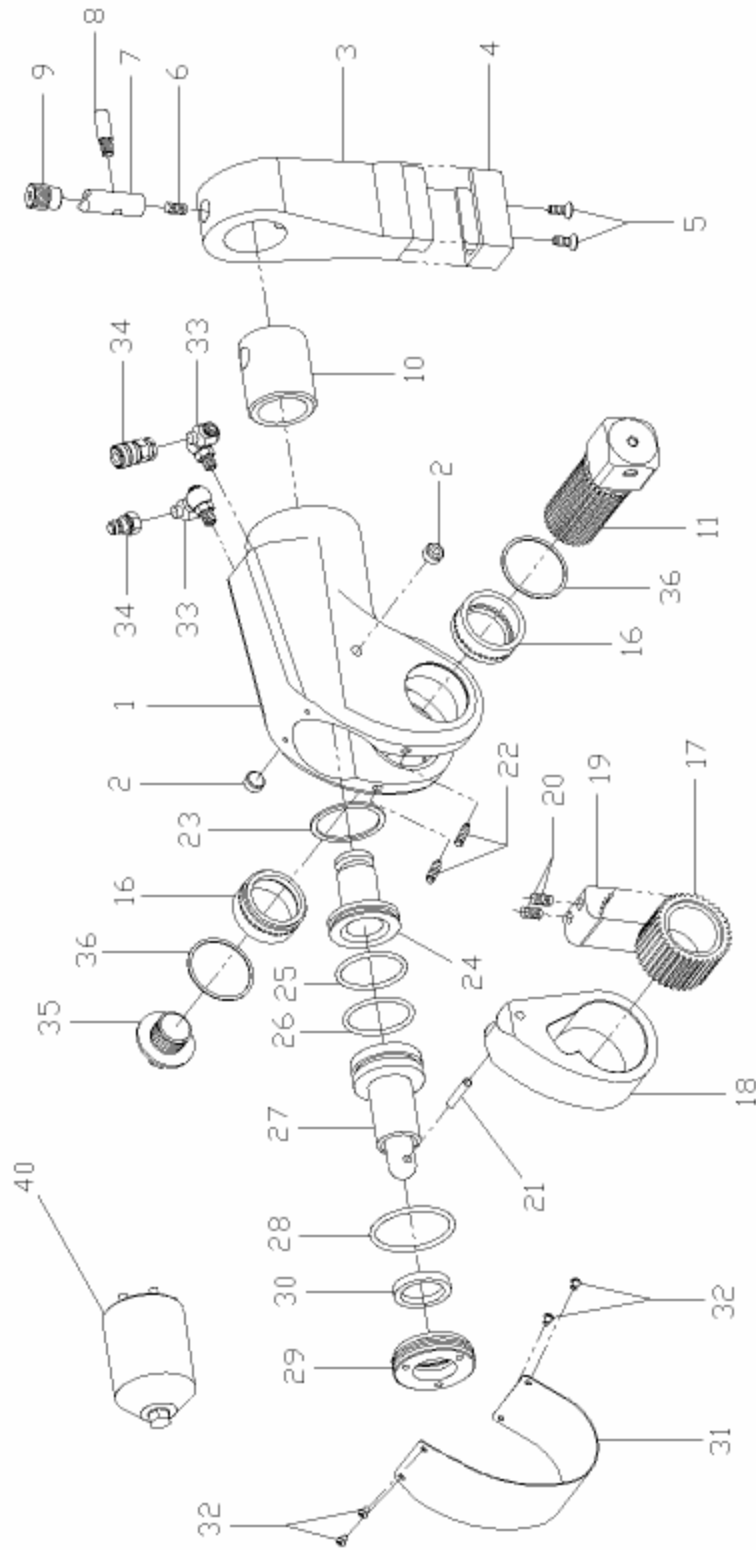

Part Numbers for Ordering						
	Part	TU-2	TU-3	TU-7	TU-11	TU-27
1	Housing	TU-2-01	TU-3-01	TU-7-01	TU-11-01	TU-27-01
2	Housing Threaded Plug	N/A	N/A	N/A	TU-11-39	TU-27-39
3	Reaction Arm	TU-2-03-1	TU-3-03-1	TU-7-03-1	TU-11-03-1	TU-27-03-1
4	Reaction Arm Cover	TU-2-03-7	TU-3-03-7	TU-7-03-7	TU-11-03-7	TU-27-03-7
5	Cover Screws	TU-2-03-8	TU-3-03-8	TU-7-03-8	TU-11-03-8	TU-27-03-8
6	Reaction Arm Spring	TU-2-03-6	TU-3-03-6	TU-7-03-6	TU-11-03-6	TU-27-03-6
7	Locking Pin	TU-2-03-3	TU-3-03-3	TU-7-03-3	TU-11-03-3	TU-27-03-3
8	Retract Button	TU-2-03-4	TU-3-03-4	TU-7-03-4	TU-11-03-4	TU-27-03-4
9	Reaction Arm Screw	TU-2-03-5	TU-3-03-5	TU-7-03-5	TU-11-03-5	TU-27-03-5
10	Spline sleeve	TU-2-03-2	TU-3-03-2	TU-7-03-2	TU-11-03-2	TU-27-03-2
11	Square Drive	TU-2-11-1	TU-3-11-1	TU-7-11-1	TU-11-11-1	TU-27-11-1
12	Ball Plunger	TU-2-11-3	TU-3-11-3	TU-7-11-3	TU-11-11-3	N/A
14	Locking Pin	TU-2-11-2	TU-3-11-2	TU-7-11-2	TU-11-11-2	N/A
16	Sleeve	TU-2-13	TU-3-13	TU-7-13	TU-11-13	TU-27-13
17	Ratchet	TU-2-05	TU-3-05	TU-7-05	TU-11-05	TU-27-05
18	Drive Plate	TU-2-09	TU-3-09	TU-7-09	TU-11-09	TU-27-09
19	Drive Segment	TU-2-07	TU-3-07	TU-7-07	TU-11-07	TU-27-07
20	Drive Segment Spring	TU-2-27	TU-3-27	TU-7-27	TU-11-27	TU-27-27
21	Roll Pin	TU-2-19	TU-3-19	TU-7-19	TU-11-19	TU-27-19
22	Ball Plunger	TU-2-29	TU-3-29	TU-7-29	TU-11-29	TU-27-29
23	Smalley Ring	TU-2-43	TU-3-43	TU-7-43	N/A	TU-27-43
24	End Plug	TU-2-15	TU-3-15	TU-7-15	TU-11-15	TU-27-15
25	End Plug Seal	TU-2-37	TU-3-37	TU-7-37	TU-11-37	TU-27-37
26	Piston Seal	TU-2-33	TU-3-33	TU-7-33	TU-11-33	TU-27-33
27	Piston Rod Assembly	TU-2-17	TU-3-17	TU-7-17	TU-11-17	TU-27-17
28	Gland Seal	TU-2-35	TU-3-35	TU-7-35	TU-11-35	TU-27-35
29	Cylinder Gland	TU-2-21	TU-3-21	TU-7-21	TU-11-21	TU-27-21
30	Rod Seal	TU-2-31	TU-3-31	TU-7-31	TU-11-31	TU-27-31
31	Shroud	TU-2-23	TU-3-23	TU-7-23	TU-11-23	TU-27-23
32	Shroud Screws	TU-2-25	TU-3-25	TU-7-25	TU-11-25	TU-27-25
33	Swivel (2 req)	STU-4M-4M	STU-4M-4M	STU-4M-4M	STU-4M-4M	STU-4M-4M
34	Coupler Set	HC-S-100	HC-S-100	HC-S-100	HC-S-100	HC-S-100
35	Threaded Retainer	N/A	N/A	N/A	N/A	TU-27-11-6
36	Sleeve Retainer Clips	N/A	N/A	N/A	N/A	TU-27-41
40	Gland Wrench	TU-2-GW	TU-3-GW	TU-7-GW	TU-11-GW	TU-27-GW
~	Reaction Arm Assembly	TU-2-03	TU-3-03	TU-7-03	TU-11-03	TU-27-03
~	Square Drive Assembly	TU-2-11	TU-3-11	TU-7-11	TU-11-11	TU-27-11

TU – 60 Series Wrench

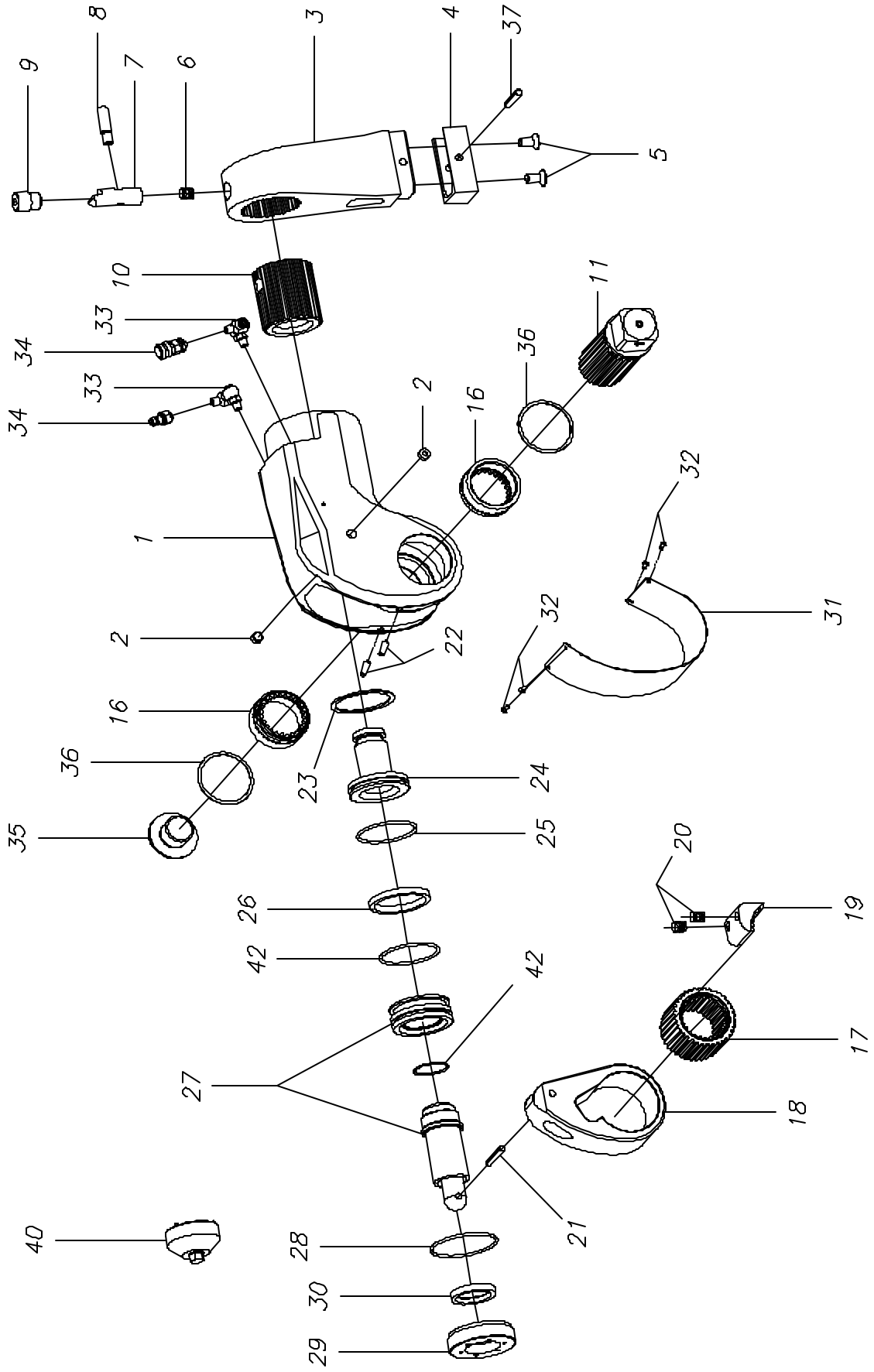

Part Numbers for Ordering		
	Part	TU-60
1	Housing	TU-60-01
2	Housing Threaded Plug	TU-60-39
3	Reaction Arm	TU-60-03-1
4	Reaction Arm Cover	TU-60-03-7
5	Cover Screws	TU-60-03-8
6	Reaction Arm Spring	TU-60-03-6
7	Locking Pin	TU-60-03-3
8	Retract Button	TU-60-03-4
9	Reaction Arm Screw	TU-60-03-5
10	Spline sleeve	TU-60-03-2
11	Square Drive	TU-60-11-1
12	Ball Plunger	N/A
13	Square Drive Spring	N/A
14	Locking Pin	N/A
15	Hollow Lock	N/A
16	Sleeve	TU-60-13
17	Ratchet	TU-60-05
18	Drive Plate	TU-60-09
19	Drive Segment	TU-60-07
20	Drive Segment Spring	TU-60-27
21	Roll Pin	TU-60-19
22	Ball Plunger	TU-60-29
23	Smalley Ring	TU-60-43
24	End Plug	TU-60-15
25	End Plug Seal	TU-60-37
26	Piston Seal	TU-60-33
27	Piston Rod Assembly	TU-60-17-1
28	Gland Seal	TU-60-35
29	Cylinder Gland	TU-60-21
30	Rod Seal	TU-60-31
31	Shroud	TU-60-23
32	Shroud Screws	TU-60-25
33	Swivel (2 req)	STU-4M-4M
34	Coupler Set	HC-S-100
35	Threaded Retainer	TU-60-11-6
36	Sleeve Retainer Clips	TU-60-41
37	COVER ROLL PIN	TU-60-03-9
40	Gland Wrench	TU-60-GW
41	PISTON INNER SEAL	TU-60-33
42	PISTON OUTER SEAL	TU-60-34

Maintenance Section

WARNING

Always turn off the power supply, bleed off hydraulic fluid from the hose connections on the cylinder assembly and disconnect the hoses before attempting to repair or perform maintenance on this tool. Always wear eye protection when operating or performing maintenance on this tool.

DISASSEMBLY

General Instructions

1. Do not disassemble the tool any further than necessary to replace or repair damaged parts.
2. Use extra care not to score, nick or damage surfaces that will contain hydraulic oil under pressure.
3. Whenever grasping a tool in a vise, always use leather-covered or copper-covered vise jaws to protect the surface of the part and help prevent distortion. This is particularly true of threaded members and housings.
4. Do not remove any part that is a press fit in or on an assembly unless the removal of that part is necessary for repairs or replacement.
5. Do not disassemble the hydraulic cylinder assembly unless you have a complete set of seals and o-rings for replacement.
6. Use only British Standard fractional size tools when disassembling these tools.

Disassembly of the Reaction Arm Assembly

1. Push the Reaction Arm Retract Button (8) toward the Reaction Arm Boot (4) and separate the Reaction Arm Assembly from the Housing (1).
2. While holding the Button down, use a hex wrench to unscrew and remove the Reaction Arm Spline Screw (9).
3. Apply some downward pressure to the Reaction Arm Engagement Pin (7) and unscrew the Reaction Arm Retract Button from the Engagement Pin.
4. Remove the Engagement Pin by sliding it out of the top of the Reaction Arm (3).
5. Pull the Reaction Arm Splined Sleeve (10) out of the Reaction Arm.
6. Using a hooked tool through the Spline Screw opening, pull the Reaction Arm Pin Spring (6) out of the Reaction Arm.
7. To remove the Reaction Arm Boot, use a hex wrench to unscrew the two Boot Mounting Screws (5) and pull the Boot off the Reaction Arm.

Disassembly of the Square Drive Tool

1. Before attempting to disassemble a square drive tool, connect the tool to a pump and operate the tool until the Piston Assembly (27) is in the fully retracted position.
2. Grasp the Housing (1) in copper-covered or leather-covered vise jaws with the inlet end upward and using a

- 3/4" wrench, unscrew and remove the two Swivel Inlets (33) with their attached Couplers (34).
3. Remove the Housing from the vise jaws and with the inlet openings over a container to catch the oil, drain as much hydraulic oil as possible from the Housing.
4. Grasp the Cylinder Housing in copper-covered or leather-covered vise jaws with the Shroud (31) upward.

CAUTION

In the following step the Shroud will spring to a straightened position when the Screws at one end are removed. Hold the Shroud in position until the Screws are removed and control the flex of the loose end.

5. Use a hex wrench to unscrew and remove the Shroud Mounting Screws (32). Remove the Shroud.
6. **For TU-11, TU-27 models and TU-60**, use a hex wrench to unscrew and remove the Retract Pin Hole Plugs (2) from each side of the Housing.
7. If the Piston Assembly is not fully retracted, use a brass drift or brass hammer to tap the Assembly inward until the Retract Pin (21) aligns with the cross holes in the Housing. Use a small drift to tap the Retract Pin out of the Drive Plate (18) and Piston Assembly through the openings in the Housing.
8. **For TU-2, TU-3, TU-7 and TU-11 models**, insert a hex wrench through the larger opening in the Square Drive and unscrew the Square Drive Locking Pin (14) inward against the Square Drive Spring (13) while pulling or pushing the Square Drive out of the tool. **For TU-27 model and TU-60**, unscrew and remove the Square Drive Retaining Screw (35). Pull the Square Drive out of the tool.
9. **For TU-2, TU-3, TU-7 and TU-11 models**, remove the Drive Plate, assembled with the Ratchet (17), Segment Pawl (19) and Segment Pawl Springs (20) from between the ears of the Housing. Using finger pressure, push the Drive Sleeves (16) inward to remove them from the Housing.
10. **For TU-27 model and TU-60**, remove the two Drive Sleeve Retainers (36) from the Housing. Pull one of the Drive Sleeves (16) out of the Housing and while holding the Drive Plate, the Ratchet (17), Segment Pawl (19) and Segment Pawl Springs (20), pull the remaining Drive Sleeve out of the Housing. Slide the assembled Drive Plate out of the Housing.
11. Being careful not to let the springs eject from the assembly, slide the Ratchet, Segment Pawl and Segment Pawl Springs out of the Drive Plate.

NOTICE

The Cylinder Gland is staked into the Housing to prevent it from loosening due to vibration or turbulence in the hydraulic oil flow. The stake point must be drilled out before attempting to remove the Cylinder Gland.

12. Locate the stake point on the threads of the Cylinder Gland (29) and Housing. Using a 1/16" drill bit centered on the stake point, drill approximately 3/32" deep in one continuous motion to remove the thread and interference at that point.

13. Engage the pins of the Cylinder Gland Wrench (40) with the holes in the Cylinder Gland and using a socket on the hex of the Wrench unscrew and remove the Cylinder Gland. Should the Gland not rotate freely after initial breakout, additional drilling, in small increments, may be required to remove the obstruction.

14. If the Piston Rod Seal (30) must be replaced, remove it from the central opening of the Gland.

15. If the Cylinder Gland Seal (28) must be replaced, remove it from the groove at the bottom of the threads in the Housing.

NOTICE

In the following step, DO NOT grasp the shaft of the Piston Assembly with any device that will mar, bur or otherwise damage the shaft or the drive plate end of the shaft.

16. Pull the Piston Assembly out of the Housing. If the Assembly is tight in the Housing and difficult to pull, inject air into the inlet opening while holding the Housing over a container that will not damage the Piston when it is expelled. If an air hose is not available, temporarily attach the advance line from the pump and cycle the tool to advance the Piston out of the Housing. Hydraulic oil will be emitted with the Piston, so the assembly must be held over a non-damaging container.

17. If the Piston Seal (26) must be replaced, remove it from the Piston.

18. Push on the small end of the End Plug (24) to remove it from the Housing. If the End Plug is tight in the Housing, insert a flat face drift into the hole in the center of the small shaft, and without cocking the Plug, tap it out of the Housing.

19. If the End Plug Seal (25) must be replaced, remove it from the End Plug.

20. If the Splined Sleeve Seat (23) needs replacement, use a thin blade screwdriver to work it out of the groove in the Housing.

ASSEMBLY

General Instructions

1. Use extra care not to score, nick or damage surfaces that will contain hydraulic oil under pressure.

2. Whenever grasping a tool in a vise, always use leather-covered or copper-covered vise jaws to protect

the surface of the part and help prevent distortion. This is particularly true of threaded members and housings.

3. Apply o-ring lubricant to all o-rings before final assembly.

Assembly of the Square Drive Tool

1. If the Splined Sleeve Seat (23) was removed from the Housing (1), install it in the internal groove near the inlet end of the Housing.

2. Grasp the Housing in leather-covered or copper-covered vise jaws with the inlet end downward.

3. Apply o-ring lubricant to the End Plug Seal (25) and install it in the annular groove at the large end of the End Plug (24).

4. Insert the assembled End Plug, small end leading, into the piston bore of the Housing and using a brass drift in the center of the End Plug; tap the assembly to the bottom of the bore without cocking it.

5. Apply o-ring lubricant to the Piston Seal (26) and install it in the annular groove at the large end of the Piston Assembly (27).

6. If the Piston Rod Seal (30) was removed from the Cylinder Gland (29), install a new Seal, lip end trailing, into the central opening of the Gland.

7. Apply o-ring lubricant to the Cylinder Gland Seal (28) and install it in the housing recess at the bottom of the threads for the Cylinder Gland.

8. Insert the Piston Assembly, shaft end leading, into the threaded end of the Gland through the Gland Seal and push it inward until the large end of the Piston is against the end of the Gland.

9. Start threading the Cylinder Gland into the Housing. Using the Cylinder Gland Wrench (40) and a socket, tighten the Gland in the Housing.

10. Reposition the assembled tool in the vise jaws with the inlet end upward.

11. Wrap the threads of the Swivel Sets (33) with Teflon Tape. Thread the swivel with the male hose Coupler (34) into the threaded hole on the right (Marked A) side of the Housing when looking from the inlet end of the tool with the Square Drive downward. Thread the swivel with the female hose Coupler into the other hole (Marked R).

12. Connect the hoses from the pump, turn the power on and cycle the tool several times to determine if the Gland is leaking fluid.

13. **If the Gland is leaking**, disconnect the hoses and power supply, determine the cause of the leak and take whatever steps are necessary to correct the problem.

If the Gland is not leaking, operate the tool to fully retract the Piston Assembly, disconnect the hoses and power supply and reposition the tool in the vise jaws with the inlet end downward.

NOTICE

In the following step, the Cylinder Gland must be staked into the Housing to prevent it from loosening due to vibration or turbulence in the hydraulic oil flow. Use a center punch with a 60 degree included angle and do not deform the stake point beyond 3/64" deep. Do not attempt to use the previously staked position and leave housing clearance at the new position for a 1/16" drill bit should the Gland require removal in the future.

14. Stake the thread of the Gland and Housing at the open area between the ears of the Housing that holds the Square Drive (11). Make certain both the Housing and Gland are deformed at the stake point.

15. If the Ball Plungers (22) were removed, install them in the Housing and thread them inward until only the ball projects into the driver sleeve opening.

16. Wipe a thin film of Mobil 1 ® Synthetic Grease on the sides of the Drive Plate (18), as well as the inner race and piston rod recess of the Drive Plate.

17. Insert the Ratchet (17) in the Drive Plate.

18. Position the Segment Pawl (19) at the cavity in the Drive Plate. Make certain the teeth of the Pawl will properly engage the teeth of the Ratchet. If they will not engage properly, reverse the Ratchet in the Drive Plate.

Insert the Segment Pawl Springs (20) into the holes in the Pawl, and while compressing the springs with finger pressure, slide the Pawl and springs into the Drive Plate.

19. **For TU-2, TU-3, TU-7 and TU-11 models**, proceed as follows:

- a) a) From inside the housing ears, insert a Driver Sleeve (16) into each ear with the detent end of the Sleeve trailing. The ball of the Ball Plunger must engage the detent holes encircling the Sleeve.
- b) b) Position the assembled Drive Plate between the ears of the Housing with the notch for the piston rod toward the rod end.
- c) c) Insert a wire rod or hex wrench through the opening of the Square Drive Hollow Lock (15) and push the Square Drive Locking Pin (14) inward against the Square Drive Spring (13) while inserting the Square Drive (11) into the Ratchet. It may be necessary to individually rotate the Driver Sleeves and Ratchet to align the squares for the Square Drive.

For TU-27 model and TU-60, proceed as follows:

- a) Position the assembled Drive Plate between the ears of the Housing with the notch for the position rod toward the rod end.
- b) From the outside of the housing ears, insert a Driver Sleeve (16) into each ear with the small hub end leading. The small hub must enter the recess on each side of the Drive Plate. Then insert Sleeve Retainer Clips (36) into groove to retain Sleeves (24).

NOTICE

In the following step, the side of the Housing that the square protrudes from will determine the direction of

square drive rotation. If the square extends to the left side when looking from the inlet end of the Housing, rotation will be clockwise to tighten. A right side extension is counterclockwise for loosening.

- c) Insert the splined end of the Square Drive (11) through the Driver Sleeves and Ratchet. Install the Square Drive Retaining Screw (35) in the end of the Square Drive and tighten it.

20. Insert the Retract Pin (21) into the hole in the Drive Plate through the hole in the Housing. Use a drift and hammer to tap the Pin into the Plate and rod to secure the assembly. Make certain the Pin does not protrude beyond the sides of the Drive Plate.

21. **For TU-11, TU-27 models and TU-60**, use a hex wrench to install the two Retract Pin Hole Plugs (2) flush with the sides of the Housing.

22. Place one end of the Shroud (31) on the Housing and using a hex wrench, install the Shroud Mounting Screws (32) at that end.

23. Bend the Shroud around the Housing and install the remaining Mounting Screws.

Assembly of the Reaction Arm Assembly

1. If the Reaction Arm Boot (4) was removed, push it onto the end of the Reaction Arm (3) and using a hex wrench, secure it by installing the two Boot Mounting Screws (5).
2. Insert the Reaction Arm Pin Spring (6) in the downward, blind hole below the bore for the Reaction Arm Splined Sleeve (10).
3. Position the Reaction Arm Splined Sleeve in the bore of the Reaction Arm with the small hub end trailing and the slightly larger hole through the side of the Sleeve upward. Align the holes through the Sleeve with the holes in the Reaction Arm.
4. Insert the Reaction Arm Engagement Pin (7), flat end leading, through the Sleeve into the hole against the Pin Spring. Rotate the Pin so that the vertical flat on the end of the Pin faces away from the tool end of the Arm.
5. Push downward on the Engagement Pin until the threaded hole in the side of the Pin is visible through the slot in the end of the reaction arm away from the tool.
6. **For TU-2, TU-3, TU-7 and TU-11 models**, apply a suitable thread-locking compound to the threads of the Reaction Arm Retract Button (8) and using a screwdriver, screw the Button tightly into the threaded hole in the Engagement Pin.
- For TU-27 model and TU-60**, apply a suitable thread-locking compound to the threads of the Reaction Arm Retract Button (8) and using a hex wrench, screw the Button tightly into the threaded hole in the Engagement Pin (7).
7. Using a hex wrench, thread the Reaction Arm Spline Screw (9) into the top of the Reaction Arm until the unthreaded end enters the hole in the Splined Sleeve and the threads bottom out.

Troubleshooting Guide		
Trouble	Probable Cause	Solution
Piston will not advance or retract	Couplers are not securely attached to the tool or pump	Check the Coupler connections and make certain that they are connected.
	Coupler is defective	Replace any defective Coupler.
	Defective remote control switch	Replace the switch and/or control pendent
	Dirt in the direction-control valve of the pump unit	Disassemble the pump and clean the direction-control valve.
Piston will not retract	Hose connections reversed	Make certain the advance on the pump is connected to the advance on the tool and retract on the pump is connected to the retract on the tool.
	Retract hose not connected	Connect the retract hose securely
	Retract pin broken	Replace the broken pin and/or spring
Cylinder will not build up pressure	Piston Seal and/or End Plug Seal leaking	Replace any defective O-rings
	Coupler is defective	Replace any defective Coupler
Square Drive will not turn	Grease or dirt build up in the teeth of the Ratchet and Segment Pawl	Disassemble the Ratchet and clean the grease or dirt out of the teeth
	Worn or broken teeth on Ratchet an/or Segment Pawl	Replace any worn or damaged parts
Tool tightens immediately when turned on	Hose connections are reversed	Depress the advance button to release the tool; shut the pump off in the advance position and reverse the hose connection
Pump will not build up pressure	Defective relief valve	Inspect, adjust or replace the relief valve
	Air supply too low or air hose too small	Make certain the air supply and hose size comply with the pump manual recommendations.
	Electric power source is too low	Make certain the amperage, voltage and any extension cord size comply with the pump manual requirements
	Defective Gauge	Replace the Gauge
	Low oil level	Check and fill the pump reservoir
	Clogged filter	Inspect, clean and/or replace the pump filter
Pressure reading erratic	Defective Gauge	Replace the Gauge
Nut Returns with retract stroke	Ball Plungers are not engaging the Drive Sleeves	Thread the Ball Plungers to the correct depth in the Housing.

NOTICE

SAVE THESE INSTRUCTIONS. DO NOT DESTROY.