

TX Series



Operating and Maintenance Instructions For TX Series Hydraulic Torque Wrenches



1025 Conroy Place, Easton PA 18040
Phone: 610-250-5800 * Fax: 610-250-2700
Toll-Free: 1-888-TORCUP-1

E-mail: sales@torcup.com * Website: www.torcup.com



OPERATION AND MAINTENANCE MANUAL FOR TorcUP TX-2, TX-4, TX-8, TX-16, TX-32 and TX-45 LOW PROFILE HYDRAULIC TORQUE WRENCHES

NOTICE

Series TX-2, TX-4, TX-8, TX-16, TX-32 and TX-45 Low Profile Hydraulic Torque Wrenches are designed for installing and removing large bolts having minimal wrench clearance at offshore platforms, power plants, steel erection sites and other locations requiring precise high torque during bolt makeup and maximum torque for bolt breakdown.

TorcUP Inc. is not responsible for customer modification of tools for applications on which TorcUP Inc. was not consulted.

WARNING

IMPORTANT SAFETY INFORMATION ENCLOSED.

READ THIS MANUAL BEFORE OPERATING TOOL.

IT IS THE RESPONSIBILITY OF THE EMPLOYER TO PLACE THE INFORMATION IN THIS MANUAL INTO THE HANDS OF THE OPERATOR.

FAILURE TO OBSERVE THE FOLLOWING WARNINGS COULD RESULT IN INJURY.

PLACING TOOL IN SERVICE

- Always operate, inspect and maintain this tool in accordance with American National Standards Safety Code for Hydraulic Rams and Jacks (ANSI B30.1)
- This tool will function using an air or electric powered hydraulic pump. Adhere to the pump safety requirements and follow instructions when connecting the pump to the tool.
- Use only equipment rated for the same pressure and torque.
- Use only a hydraulic pump capable of generating 10,000 psig (681 bar) maximum pressure with this tool.
- Use only twin line hydraulic hose rated for 10,000 psig (681 bar) pressure with this tool.
- Do not interchange the male and female swivel inlets on the tool or the connections on one end of the hose. Reversing the inlets will reverse the power stroke cycle and may damage the tool.
- Do not use damaged, frayed or deteriorated hoses and fittings. Make certain there are no cracks, splits or leaks in the hoses.

- Use the quick connect system to attach the hoses to the tool and pump. Make certain the spring-loaded retaining rings are fully engaged and the safety rings are tightly threaded against the spring-loaded retaining rings to prevent the connectors from disengaging under pressure.
- When connecting hoses that have not been preloaded with hydraulic oil, make certain the pump reservoir is not drained of oil during start-up.
- Do not remove any labels. Replace any damaged labels.

USING THE TOOL

- Do not handle pressurized hoses. Escaping oil under pressure can penetrate the skin, causing serious injury. If oil is injected under the skin, see a doctor immediately.
- Never pressurize uncoupled couplers. Only use hydraulic equipment in a coupled system.
- Always wear eye protection when operating or performing maintenance on this tool.
- Always wear head and hand protection and protective clothing when operating this tool.

NOTICE

The use of other than genuine TorcUP replacement parts may result in safety hazards, decreased tool performance, and increased maintenance, and may invalidate all warranties.

Repairs should be made only by authorized personnel. Consult your nearest TorcUP Authorized Servicenter. Refer All Communications to the Nearest TorcUP Office or Distributor.

TorcUP Inc. 2000
Printed in U.S.A.

**For Technical Support and Information Contact:
TorcUP, Inc.
1025 Conroy Place, Easton, PA 18040
Toll Free: (888) TORCUP-1 Fax: (610) 250-2700
E-mail: info@torcup.com**

WARNING

FAILURE TO OBSERVE THE FOLLOWING WARNINGS COULD RESULT IN INJURY

USING THE TOOL

- Keep hands, loose clothing and long hair away from the reaction arm and working area during operation. Do not attempt to support the tool with your hands during operation.
- This tool will exert a strong reaction force. Use proper mechanical support and correct reaction arm positioning to control these forces. Do not position the reaction arm so that it tilts the tool off the axis of the bolt and never use the swivel inlets as a reaction stop.
- Avoid sharp bends and kinks that will cause severe back-up pressure in hoses and lead to premature hose failure.
- Use accessories recommended by TorcUP.
- Use only impact sockets and accessories. Do not use hand (chrome) sockets or accessories.
- Use only sockets and accessories that correctly fit the bolt or nut and function without tilting the tool off the axis of the bolt.
- This tool is not designed for working in explosive atmospheres
- This tool is not insulated against electric shock. When using this tool with a pump having an electrical power source or circuits, follow the pump instructions for proper grounding.

Always wear eye protection when operating or performing maintenance on this tool.



Always wear ear protection when operating this tool.



Always turn off the pump and disconnect the power before installing, removing, or adjusting any accessory on this tool, or before performing any maintenance on this tool.



The Torque Reaction Arm must be positioned against a positive stop. Do not use the Arm as a dead handle. Take all precautions to make certain the operator's hand cannot be pinched between the Arm and a solid object.

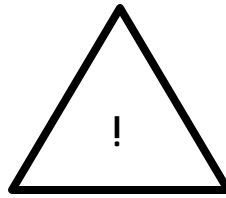

Operate at 10,000 psig (681 bar) maximum pressure.

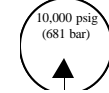

Keep body stance balanced and firm. Do not overreach when operating this tool.



Do not carry the tool by the hose.



Do not use damaged, frayed or deteriorated hydraulic hoses and fittings.



PLACING THE TOOL IN SERVICE

CONNECTING THE TOOL

1. Attach the twin line hose to the swivel inlets of the Low Profile Driver Assembly using the spring-loaded quick connect ends. After making certain that they are fully engaged, thread the safety rings tightly against the spring-loaded retainer rings.
2. Connect the opposite ends of the hose to the Pump in the same manner.
3. Push the Link Retaining Pin out of the Low Profile Drive Cylinder.
4. Mate the selected Ratchet Link to the Cylinder by inserting the end of the Cylinder opposite the Swivel Inlets between the Side Plates of the Ratchet Link. (Refer to Dwg. 1)
5. Align the Holes for the Link Retaining Pin and insert the Pin through the side plates and Cylinder to keep the units joined together.

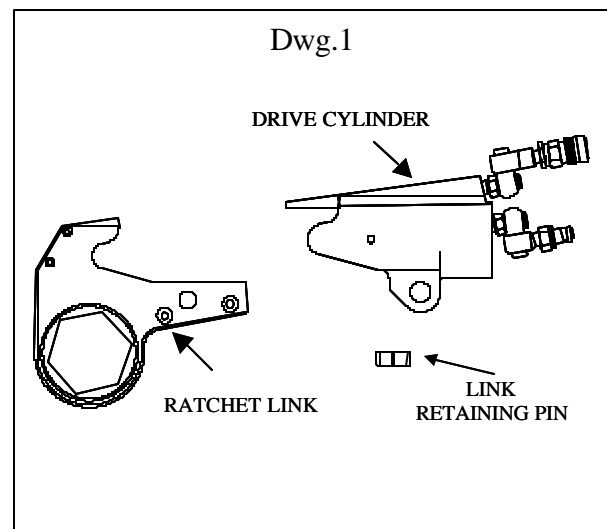

PLACING THE TOOL IN SERVICE

ADJUSTMENTS

SETTING THE TORQUE

After determining the desired torque, use the torque conversion charts on pages 4 and 5 to determine the pressure that is necessary to achieve that torque.

1. Connect the tool to the power supply and turn the pump on.
2. Depress the remote control button causing the pressure to be shown on the gauge.
3. Adjust the pressure by loosening the wing nut that locks the pressure adjustment thumbscrew. Rotate the thumbscrew clockwise to increase the pressure and counterclockwise to decrease the pressure. When decreasing pressure, always lower the pressure below the desired point and then bring the gauge back up to the desired pressure.
4. When the desired pressure is reached, retighten the wing nut and cycle the tool again to confirm that the desired pressure setting has been obtained.

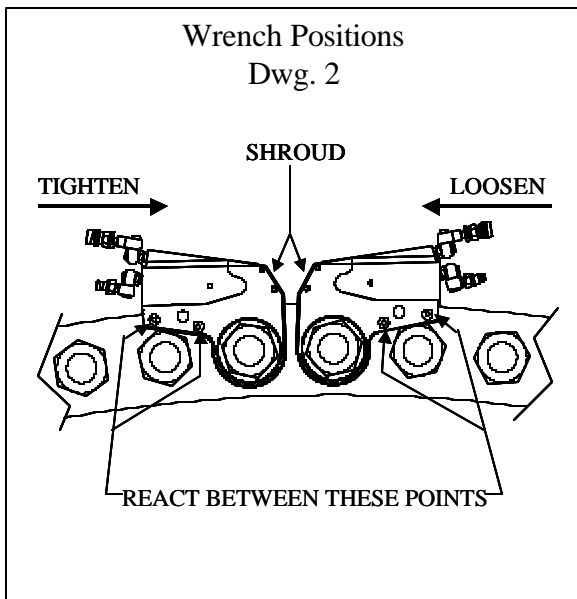

OPERATING THE WRENCH

The position of the tool relative to the nut determines whether the action will tighten or loosen the nut. (Refer to Dwg. 2 for application examples). The power stroke of the Piston Assembly will always turn the Ratchet Hex toward the Shroud. 1. Place the Ratchet Hex on the nut. Make certain it is the correct size for the nut and that it fully engages the nut.

2. Position the reaction surface against an adjacent nut, flange or solid system component. Make certain that there is clearance for the hoses, swivels, and inlets. **DO**

NOT allow the tool to react against the hoses, swivels, or inlets.

3. After having turned the Pump on and presetting the pressure for the correct torque, depress the remote control button to advance the Piston Assembly. If the notch in the piston rod did not engage the Retract Pin in the Ratchet Link when the Link was joined to the Housing, it will engage the Pin automatically during the first advance stroke.
4. When the Link is connected to the Housing and the wrench is started, the reaction surface of the wrench will move against the contact point and the nut will begin to turn.
5. When the nut is no longer turning and the Pump Gauge reaches the preset pressure, release the remote control button. The piston rod will retract when the button is released and under normal conditions, an audible "click" will be heard as the tool resets itself.
6. Continue to cycle the tool until it "stalls" and the preset psi/torque has been attained.
7. Once the nut stops rotating, cycle the tool one last time to achieve total torque.

LUBRICATION

Mobil 1 ® Synthetic Grease

Lubrication frequency is dependent on factors known only to the user. The amount of contaminants in the work area is one factor. Tools used in a clean room environment will obviously require less service than a tool used out-doors and dropped in loose dirt or sand. Mobil 1 ® Synthetic Grease is formulated not to wash out of the tool in areas where lubrication is critical.

Whenever lubrication is required, lubricate as follows:

1. Separate the Low Profile Cylinder from the Ratchet Link if they are joined.
2. After wiping of the old grease, apply a daub of Mobil 1 ® Synthetic Grease to the hooking notch in the Piston rod and wipe a film of Mobil 1 ® onto the sides and faces of the two Sliders.
3. Disassemble the Ratchet Link as instructed in the Maintenance Section and wash the components in a suitable cleaning solution in a well-ventilated area.
4. Dry the components, then wipe a film of Mobil 1 ® Synthetic Grease onto the wear surface of both Side Plate Sleeves and the hubs of the Ratchet.
5. Spread a light film of Mobil 1 ® Synthetic Grease onto the inner faces of both Side Plates covering the area where the Drive and Segment Pawl travel. **DO NOT** pack the teeth of the Segment Pawl or Ratchet with lube. It can prevent the teeth from engaging properly.
6. Reassemble the Ratchet Link as instructed in the Maintenance Section.

Bar/N.M.								
Hex Sizes Bar	TX-2		TX-4	TX-8	TX-16		TX-32	
	3/4" to 1-13/16"	1-7/8" to 2-3/8"	All Hex Sizes	All Hex Sizes	2-5/8" to 3-15/16"	4" to 4-5/8"	2-7/16" to 4-5/8"	4-11/16" to 6-1/2"
	19 to 46MM N.m.	47 to 60MM N.m.	All Hex Sizes N.m.	All Hex Sizes N.m.	65 to 100MM N.m.	105 to 115MM N.m.	80 to 115MM N.m.	115 to 155MM N.m.
68	260	285	535	1,125	2,115	2,250	4,324	5,016
82	312	342	644	1,357	2,535	2,700	5,260	6,019
95	365	399	752	1,590	2,955	3,150	6,195	7,022
109	416	455	854	1,822	3,382	3,600	7,130	8,025
122	469	512	962	2,055	3,802	4,051	8,066	9,028
136	522	569	1,071	2,288	4,229	4,501	8,996	10,031
150	572	626	1,179	2,528	4,650	4,951	9,871	11,035
163	625	683	1,288	2,768	5,070	5,401	10,747	12,038
177	678	740	1,389	3,008	5,490	5,851	11,623	13,041
190	728	797	1,498	3,248	5,917	6,301	12,499	14,044
204	784	868	1,606	3,489	6,337	6,751	13,374	15,047
218	832	923	1,715	3,762	6,764	4,826	14,250	16,050
231	885	981	1,823	4,034	7,185	7,651	15,126	17,053
245	937	1,038	1,925	4,307	7,605	8,101	16,002	18,057
258	990	1,097	2,033	4,579	8,032	8,551	16,877	19,060
272	1,045	1,159	2,142	4,853	8,452	9,015	17,895	20,063
286	1,093	1,212	2,250	5,063	8,879	9,466	18,790	21,066
299	1,145	1,270	2,359	5,275	9,299	9,916	19,685	22,069
313	1,197	1,328	2,460	5,485	9,720	10,368	20,579	23,072
326	1,250	1,385	2,569	5,696	10,147	10,818	21,474	24,075
340	1,307	1,450	2,677	5,908	10,567	11,333	22,367	25,079
354	1,353	1,507	2,786	6,152	10,987	11,786	23,266	26,082
367	1,406	1,566	2,894	6,396	11,414	12,240	24,165	27,085
381	1,457	1,624	2,996	6,640	11,834	12,692	25,064	28,088
394	1,510	1,682	3,104	6,884	12,261	13,147	25,962	29,091
408	1,567	1,742	3,213	7,128	12,682	13,692	26,861	30,094
422	1,613	1,799	3,321	7,334	13,102	14,148	27,719	31,097
435	1,666	1,857	3,430	7,540	13,522	14,604	28,577	32,101
449	1,718	1,914	3,531	7,747	13,949	15,061	29,435	33,104
462	1,769	1,972	3,640	7,953	14,369	15,518	30,460	34,107
476	1,829	2,033	3,748	8,161	14,796	15,888	31,153	35,110
490	1,873	2,089	3,857	8,386	15,217	16,342	32,044	36,113
503	1,926	2,146	3,965	8,611	15,637	16,796	32,934	37,116
517	1,979	2,204	4,067	8,837	16,064	17,250	33,825	38,119
530	2,029	2,262	4,175	9,062	16,484	17,630	34,716	39,123
544	2,090	2,325	4,284	9,289	16,911	18,314	35,605	40,126
558	2,134	2,379	4,392	9,520	17,331	18,772	36,495	41,129
571	2,187	2,437	4,501	9,754	17,752	19,231	37,386	42,132
585	2,238	2,494	4,602	9,985	18,172	19,687	38,277	43,135
598	2,291	2,553	4,711	10,219	18,599	20,146	39,167	44,138
612	2,352	2,615	4,819	10,452	19,019	20,361	40,058	45,141
626	2,394	2,669	4,928	10,701	19,446	20,814	40,947	46,145
639	2,447	2,726	5,029	10,951	19,866	21,267	41,837	47,148
653	2,498	2,784	5,138	11,200	20,287	21,718	42,726	48,151
666	2,551	2,843	5,246	11,449	20,714	22,171	43,615	49,154
680	2,614	2,908	5,355	11,699	21,141	22,503	44,504	50,157

IX Series Torque Conversion Chart

P.S.I./FT./lbs								
Hex Sizes P.S.I.	TX-2		TX-4	TX-8	TX-16		TX-32	
	3/4" to 1-13/16"	1-7/8" to 2-3/8"	All Hex Sizes	All Hex Sizes	2-5/8" to 3-15/16"	4" to 4-5/8"	2-7/16" to 4-5/8"	4-11/16" to 6-1/2"
	19 to 46MM ft./lbs.	47 to 60MM ft./lbs.	All Hex Sizes ft./lbs.	All Hex Sizes ft./lbs.	65 to 100MM ft./lbs.	105 to 115MM ft./lbs.	80 to 115MM ft./lbs.	115 to 155MM ft./lbs.
1,000	192	210	395	830	1,560	1,660	3,190	3,700
1,200	230	252	475	1,001	1,870	1,992	3,880	4,440
1,400	269	294	555	1,173	2,180	2,324	4,570	5,180
1,600	307	336	630	1,344	2,495	2,656	5,260	5,920
1,800	346	378	710	1,516	2,805	2,988	5,950	6,660
2,000	385	420	790	1,688	3,120	3,320	6,636	7,400
2,200	422	462	870	1,865	3,430	3,652	7,282	8,140
2,400	461	504	950	2,042	3,740	3,984	7,928	8,880
2,600	500	546	1,025	2,219	4,050	4,316	8,574	9,620
2,800	537	588	1,105	2,396	4,365	4,648	9,220	10,360
3,000	578	640	1,185	2,574	4,675	4,980	9,866	11,100
3,200	614	681	1,265	2,775	4,990	5,360	10,512	11,840
3,400	653	724	1,345	2,976	5,300	5,644	11,158	12,580
3,600	691	766	1,420	3,177	5,610	5,976	11,804	13,320
3,800	730	809	1,500	3,378	5,925	6,308	12,450	14,060
4,000	771	855	1,580	3,580	6,235	6,650	13,201	14,800
4,200	806	894	1,660	3,735	6,550	6,983	13,861	15,540
4,400	845	937	1,740	3,891	6,860	7,315	14,521	16,280
4,600	883	980	1,815	4,046	7,170	7,648	15,181	17,020
4,800	922	1,022	1,895	4,202	7,485	7,980	15,841	17,760
5,000	964	1,070	1,975	4,358	7,795	8,360	16,500	18,500
5,200	998	1,112	2,055	4,538	8,105	8,694	17,163	19,240
5,400	1,037	1,155	2,135	4,718	8,420	9,029	17,826	19,980
5,600	1,075	1,198	2,210	4,898	8,730	9,363	18,489	20,720
5,800	1,114	1,241	2,290	5,078	9,045	9,698	19,152	21,460
6,000	1,156	1,285	2,370	5,258	9,355	10,100	19,815	22,200
6,200	1,190	1,327	2,450	5,410	9,665	10,437	20,448	22,940
6,400	1,229	1,370	2,530	5,562	9,975	10,773	21,081	23,680
6,600	1,267	1,412	2,605	5,715	10,290	11,110	21,714	24,420
6,800	1,305	1,455	2,685	5,867	10,600	11,447	22,470	25,160
7,000	1,349	1,500	2,765	6,020	10,915	11,720	22,981	25,900
7,200	1,382	1,541	2,845	6,186	11,225	12,055	23,638	26,640
7,400	1,421	1,583	2,925	6,352	11,535	12,390	24,295	27,380
7,600	1,460	1,626	3,000	6,519	11,850	12,725	24,952	28,120
7,800	1,497	1,669	3,080	6,685	12,160	13,005	25,609	28,860
8,000	1,542	1,715	3,160	6,852	12,475	13,510	26,265	29,600
8,200	1,574	1,755	3,240	7,023	12,785	13,848	26,922	30,340
8,400	1,613	1,798	3,320	7,195	13,095	14,186	27,579	31,080
8,600	1,651	1,840	3,395	7,366	13,405	14,523	28,236	31,820
8,800	1,690	1,883	3,475	7,538	13,720	14,861	28,893	32,560
9,000	1,735	1,929	3,555	7,710	14,030	15,020	29,550	33,300
9,200	1,766	1,969	3,635	7,894	14,345	15,354	30,206	34,040
9,400	1,805	2,011	3,710	8,078	14,655	15,688	30,862	34,780
9,600	1,843	2,054	3,790	8,262	14,965	16,021	31,518	35,520
9,800	1,882	2,097	3,870	8,446	15,280	16,355	32,174	36,260
10,000	1,928	2,145	3,950	8,630	15,595	16,600	32,830	37,000

TX-45 Torque Conversion Chart		
P.S.I./FT./lbs		
	TX-45	
Hex	2 7/16" to 4 5/8"	4 11/16" to 6 1/2"
Sizes	80mm to 115mm	115mm to 155mm
P.S.I.	ft./lbs.	ft./lbs.
1,000	4,685	4,852
1,200	5,415	5,779
1,400	6,145	6,706
1,600	6,875	7,633
1,800	7,605	8,560
2,000	8,338	9,485
2,200	9,180	10,440
2,400	10,022	11,395
2,600	10,864	12,350
2,800	11,706	13,305
3,000	12,548	14,260
3,200	13,422	15,202
3,400	14,296	16,144
3,600	15,170	17,086
3,800	16,044	18,028
4,000	16,921	18,970
4,200	17,762	19,914
4,400	18,603	20,858
4,600	19,444	21,802
4,800	20,285	22,746
5,000	21,130	23,690
5,200	21,978	24,637
5,400	22,826	25,584
5,600	23,674	26,531
5,800	24,522	27,478
6,000	25,372	28,425
6,200	26,192	29,378
6,400	27,012	30,331
6,600	27,832	31,284
6,800	28,652	32,237
7,000	29,475	33,190
7,200	30,328	34,143
7,400	31,181	35,096
7,600	32,034	36,049
7,800	32,887	37,002
8,000	33,740	37,955
8,200	34,562	38,877
8,400	35,382	39,799
8,600	36,202	40,721
8,800	37,022	41,643
9,000	37,840	42,565
9,200	38,706	43,528
9,400	39,572	44,491
9,600	40,438	45,454
9,800	41,304	46,417
10,000	42,170	47,380

TX-45 Torque Conversion Chart		
Bar/N.M.		
	TX-45	
Hex	2 7/16" to 4 5/8"	4 11/16" to 6 1/2"
Sizes	80mm to 115mm	115mm to 155mm
P.S.I.	N.M.	N.M.
68	6,351	6,577
82	7,341	7,834
95	8,330	9,091
109	9,320	10,347
122	10,309	11,604
136	11,303	12,858
150	12,444	14,152
163	13,586	15,447
177	14,727	16,742
190	15,869	18,036
204	17,010	19,331
218	18,195	20,608
231	19,380	21,885
245	20,564	23,162
258	21,749	24,439
272	22,938	25,716
286	24,078	26,995
299	25,218	28,275
313	26,358	29,555
326	27,498	30,834
340	28,644	32,114
354	29,793	33,398
367	30,943	34,682
381	32,092	35,965
394	33,242	37,249
408	34,394	38,533
422	35,506	39,825
435	36,617	41,117
449	37,729	42,409
462	38,841	43,700
476	39,956	44,992
490	41,113	46,284
503	42,269	47,576
517	43,425	48,868
530	44,582	50,160
544	45,738	51,452
558	46,852	52,702
571	47,964	53,952
585	49,075	55,201
598	50,187	56,451
612	51,296	57,701
626	52,470	59,007
639	53,644	60,312
653	54,818	61,617
666	55,992	62,923
680	57,166	64,228

TX-2, TX-4, TX-8 SERIES LINK

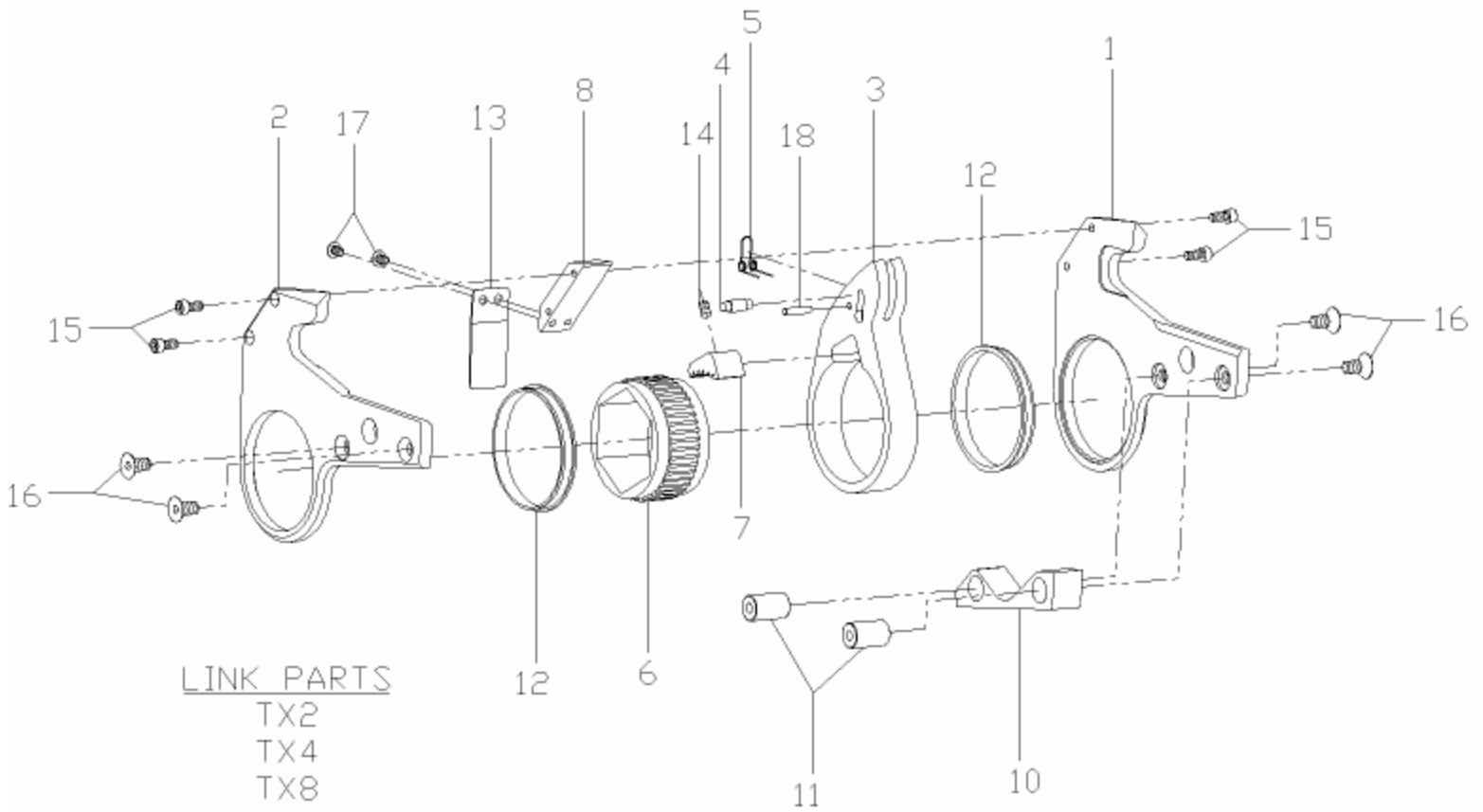

TX-16, TX-32 SERIES LINK

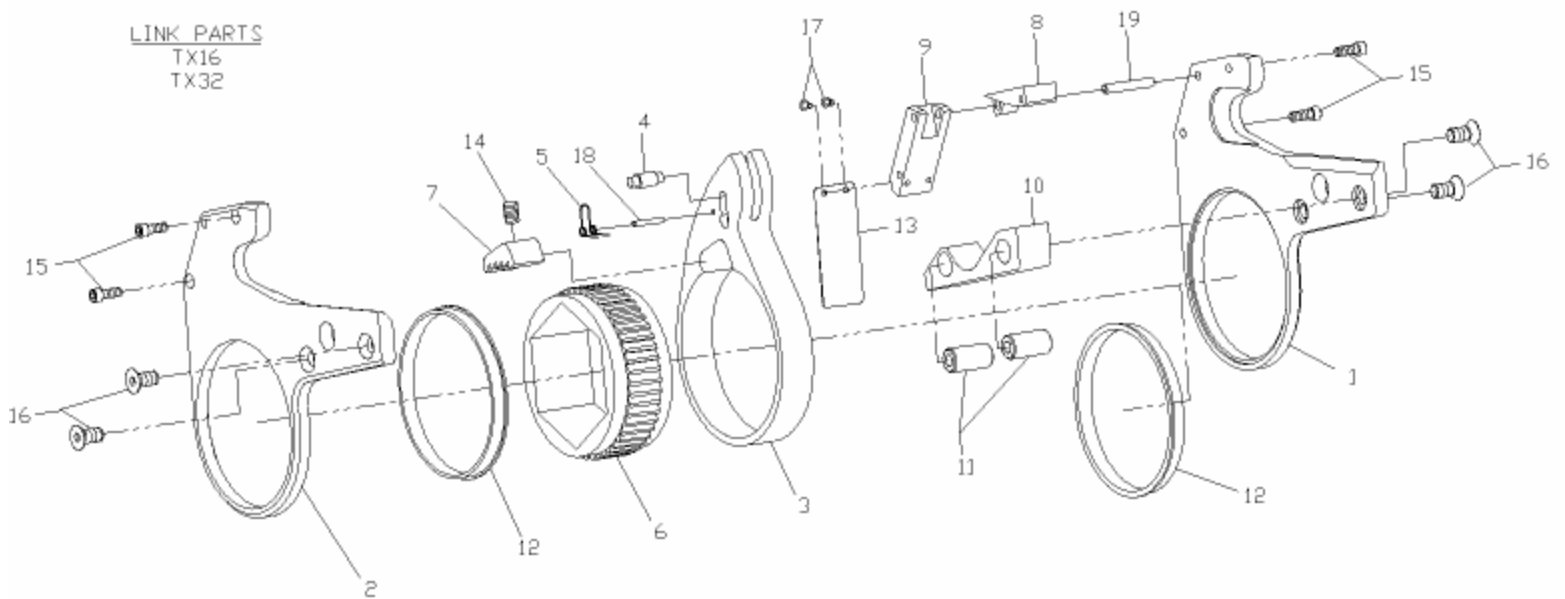

Part Numbers for Ordering (LINKS)

	Part	TX-2	TX-4	TX-8	TX-16	TX-32
1	SIDE PLATE - L	TX-2-L01	TX-4-L01	TX-8-L01	TX-16-L01	TX-32-L01
2	SIDE PLATE - R	TX-2-L02	TX-4-L02	TX-8-L02	TX-16-L02	TX-32-L02
3	DRIVE PLATE	TX-2-L03	TX-4-L03	TX-8-L03	TX-16-L03	TX-32-L03
4	DRIVE PIN	TX-2-L05	TX-4-L05	TX-8-L05	TX-16-L05	TX-32-L05
5	DRIVE PIN SPRING	TX-2-L07	TX-4-L07	TX-8-L07	TX-16-L07	TX-32-L07
6	RATCHET	TX-2-L09	TX-4-L09	TX-8-L09	TX-16-L09	TX-32-L09
7	DRIVE SEGMENT	TX-2-L11	TX-4-L11	TX-8-L11	TX-16-L11	TX-32-L11
8	UPPER SPACER	TX-2-L13	TX-4-L13	TX-8-L13	TX-16-L13	TX-32-L13
9	MIDDLE SPACER	N/A	N/A	N/A	TX-16-L14	TX-32-L14
10	LOWER SPACER	TX-2-L15	TX-4-L15	TX-8-L15	TX-16-L15	TX-32-L15
11	LOWER SPACER PIN	TX-2-L17	TX-4-L17	TX-8-L17	TX-16-L17	TX-32-L17
12	SLEEVES - SIDEPLATE	TX-2-L19	TX-4-L19	TX-8-L19	TX-16-L19	TX-32-L19
13	SHROUD	TX-2-L21	TX-4-L21	TX-8-L21	TX-16-L21	TX-32-L21
14	SEGMENT SPRING	TX-2-L25	TX-4-L25	TX-8-L25	TX-16-L25	TX-32-L25
15	SCREWS - UPPER SPACER	TX-2-L27	TX-4-L27	TX-8-L27	TX-16-L27	TX-32-L27
16	SCREWS - LOWER SPACER	TX-2-L29	TX-4-L29	TX-8-L29	TX-16-L29	TX-32-L29
17	SHROUD SCREWS	TX-2-L31	TX-4-L31	TX-8-L31	TX-16-L31	TX-32-L31
18	DRIVE PIN SPRING ROLL PIN	TX-2-L33	TX-4-L33	TX-8-L33	TX-16-L33	TX-32-L33
19	SPACER ROLL PIN	N/A	N/A	N/A	TX-16-35	TX-32-L35

TX-2, TX-4, TX-8 SERIES CYLINDER

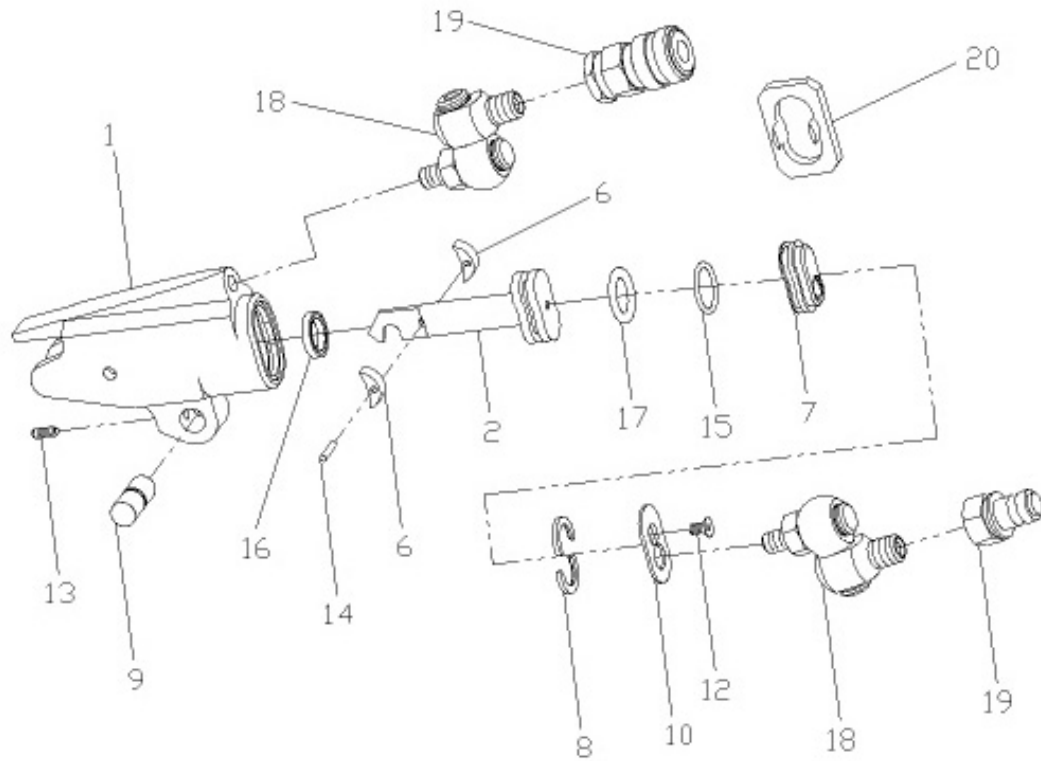

TX-16, TX-32 SERIES CYLINDER

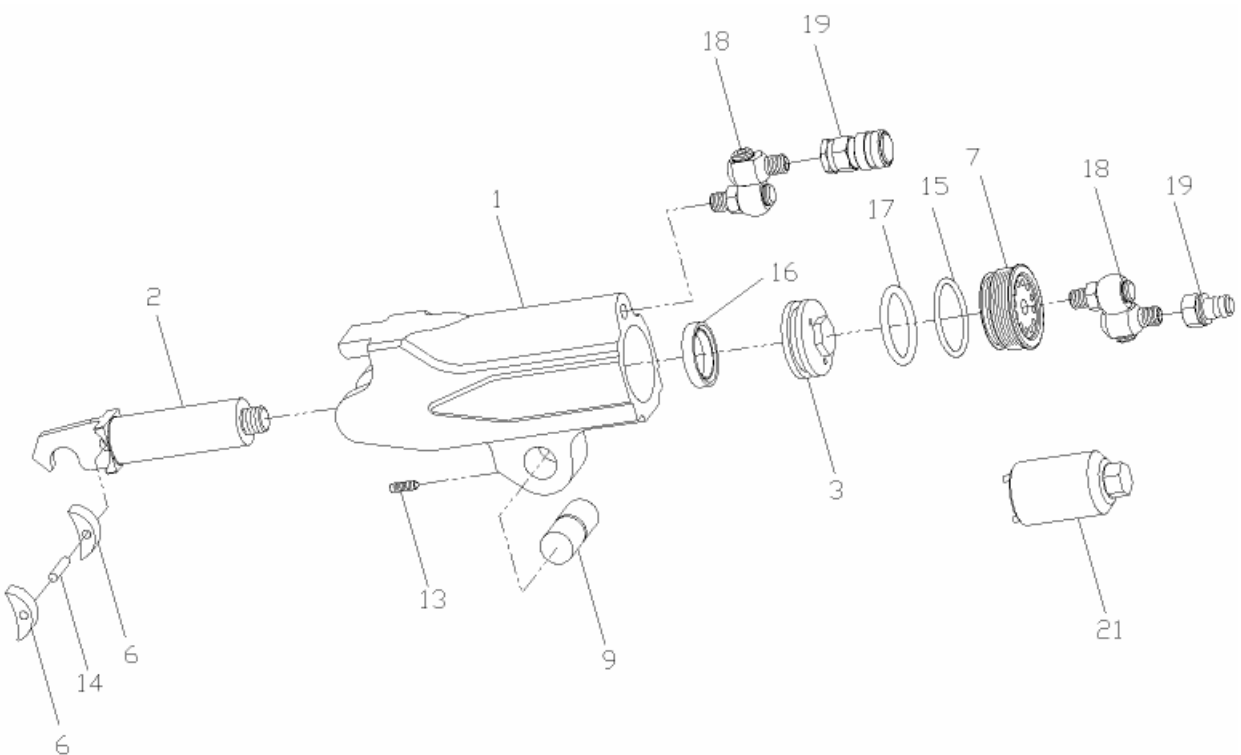

Part Numbers for Ordering (CYLINDERS)

	Part	TX-2	TX-4	TX-8	TX-16	TX-32
1	HOUSING	TX-2-C01	TX-4-C01	TX-8-C01	TX-16-C01	TX-32-C01
	PISTON ROD ASSEMBLY	TX-2-C03	TX-4-C03	TX-8-C03	TX-16-C03	TX-32-C03
2	PISTON ROD	N/A	N/A	N/A	TX-16-C03-1	TX-32-C03-1
3	PISTON CAP	N/A	N/A	N/A	TX-16-C03-2	TX-32-C03-2
	VALVE BALL	N/A	N/A	N/A	TX-16-C03-3	TX-32-C03-3
	VALVE SPRING	N/A	N/A	N/A	TX-16-C03-4	TX-32-C03-4
	VALVE HOLLOW LOCK	N/A	N/A	N/A	TX-16-C03-5	TX-32-C03-5
4	PISTON SEAL PLATE	TX-2-C05	TX-4-C05	TX-8-C05	N/A	N/A
5	SEAL RING	TX-2-C07	TX-4-C07	TX-8-C07	N/A	N/A
6	SLIDER	TX-2-C09	TX-4-C09	TX-8-X09	TX-16-C09	TX-32-C09
7	END CAP	TX-2-C11	TX-4-C11	TX-8-C11	TX-16-C11	TX-32-C11
8	RETAINING RING	TX-2-C13	TX-4-C13	TX-8-C13	N/A	N/A
9	LINK PIN	TX-2-C15	TX-4-C15	TX-8-C15	TX-16-C15	TX-32-C15
10	END COVER	TX-2-C17	TX-4-C17	N/A	N/A	N/A
11	RETAINING SCREWS	TX-2-C21	TX-4-C21	TX-8-C21	N/A	N/A
12	END COVER SCREWS	TX-2-C23	TX-4-C23	N/A	N/A	N/A
13	BALL PLUNGER	TX-2-C25	TX-4-C25	TX-8-C25	TX-16-C25	TX-32-C25
14	SLIDER PIN	TX-2-C27	TX-4-C27	TX-8-C27	TX-16-C27	TX-32-C27
15	END PLUG SEAL	TX-2-C29	TX-4-C29	TX-8-C29	TX-16-C29	TX-32-C29
16	ROD SEAL	TX-2-C31	TX-4-C31	TX-8-C31	TX-16-C31	TX-32-C31
17	PISTON O-RING	TX-2-C33	TX-4-C33	TX-8-C33	TX-16-C33	TX-32-C33
18	SWIVEL (2 Required)	N/A	STX-4M-4M	STX-4M-4M	STX-4M-4M	STX-4M-4M
18	SWIVEL (2 Required)	STX-4M-8M	N/A	N/A	N/A	N/A
19	COUPLER ASSEMBLY	HC-S-100	HC-S-100	HC-S-100	HC-S-100	HC-S-100
20	SEAL INSERTION TOOL	ATX-2-ST	ATX-4-ST	ATX-8-ST	N/A	N/A
21	END PLUG WRENCH	N/A	N/A	N/A	ATX-16-EPW	ATX-32-EPW

TX-45 Series Cylinder

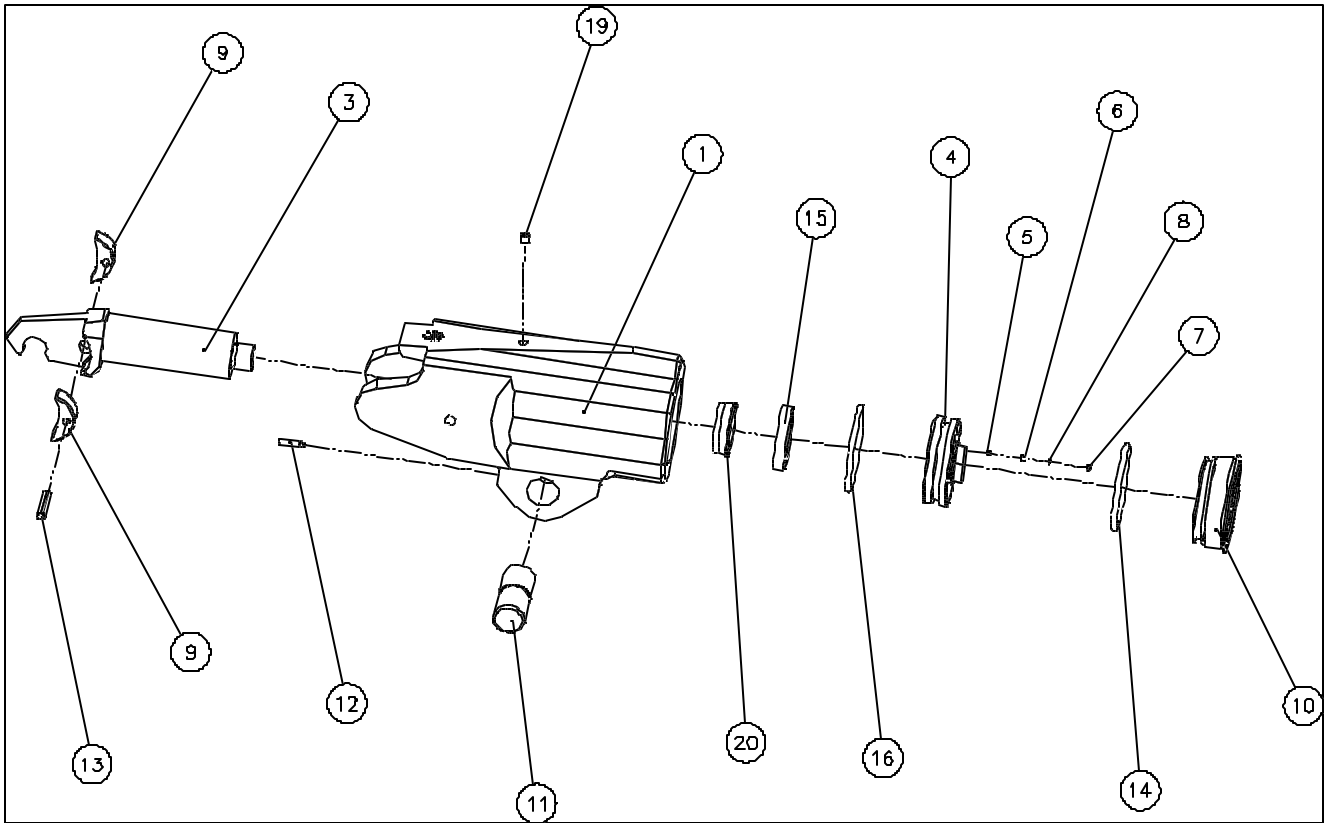

Part Numbers for Ordering (CYLINDERS)		
	Part	TX-45
1	HOUSING	TX-45-C01
2	PISTON ROD ASSEMBLY	TX-45-C03
3	PISTON ROD	TX-45-C03-1
4	PISTON	TX-45-C03-2
5	VALVE BALL	TX-45-C03-3
6	VALVE SPRING	TX-45-C03-4
7	VALVE HOLLOW LOCK	TX-45-C03-5
8	WASHER	TX-45-C03-6
9	SLIDER	TX-45-C09
10	END CAP	TX-45-C11
11	LINK PIN	TX-45-C15
12	SPRING PLUNGER	TX-45-C25
13	SLIDER PIN	TX-45-C27
14	END PLUG SEAL	TX-45-C29
15	ROD SEAL	TX-45-C31
16	PISTON O-RING	TX-45-C33
17	SWIVEL (2 Required)	STX-4M-4M
18	COUPLER ASSEMBLY	HC-S-100
19	PRESSURE PLUG	TX-45-C39
20	ROD BUSHING	TX-45-C51

Maintenance Section

WARNING

Always turn off the power supply, bleed off hydraulic fluid from the hose connections on the cylinder assembly and disconnect the hoses before attempting to repair or perform maintenance on this tool. Always wear eye protection when operating or performing maintenance on this tool.

DISASSEMBLY

General Instructions

1. Do not disassemble the tool any further than necessary to replace or repair damaged parts.
2. Use extra care not to score, nick or damage surfaces that will contain hydraulic oil under pressure.
3. Whenever grasping a tool in a vise, always use leather-covered or copper-covered vise jaws to protect the surface of the part and help prevent distortion. This is particularly true of threaded members and housings.
4. Do not remove any part that is a press fit in or on an assembly unless the removal of that part is necessary for repairs or replacement.
5. Do not disassemble the hydraulic cylinder assembly unless you have a complete set of seals and o-rings for replacement.
6. Use only British Standard fractional size tools when disassembling these tools.

Disassembly of the Tool

1. Push the Link Pin (9) out of the Housing (1) and Side Plates (1 & 2).
2. Lift the Housing from between the Side Plates and separate the two units.

Disassembly of the TX-2, TX-4, and TX-8 Cylinder Assemblies

1. Grasp the Housing (1) in copper-covered or leather-covered vise jaws with the inlet end upward and using a $\frac{3}{4}$ " wrench, unscrew and remove the two Swivel Inlets (18) with their attached Couplers (19).
2. Remove the Housing Assembly from the vise jaws and over a container to catch the oil, move the Piston Rod (2) back and forth several times to purge the hydraulic oil from the Housing.
3. Grasp the Housing in copper-covered or leather-covered vise jaws with the inlet end upward.
4. **For TX-2** use a Phillip's Head screw-driver and **TX-4 models**, use a hex wrench to unscrew and remove the End Cover Screw (12). Remove the End Cover (14).
5. Push the End Cap (7) inward approximately $\frac{1}{2}$ " and remove the two Retaining Rings (8) by working them out of the groove in the Cylinder.
6. Install the Seal Insertion Tool (20) on the inlet end of the Housing.

NOTICE

The purpose of the Seal Insertion Tool in the following step is to prevent the End Plug Seal from expanding into the Retaining Ring groove. If the Tool is not used, place two thin pieces of flat stock at the midpoint of the opening against opposite walls to control the Seal expansion.

7. Thread one of the Swivel Inlets or a threaded pipe with a tee into the End Cap (7). Use the Inlet or tee as a handle to pull the End Cap and End Plug Seal (15) out of the Housing through the Seal Insertion Tool.
8. Push the Piston Rod toward the inlet end of the Housing and using a hex wrench, unscrew and remove the two Retaining Screws (11).
9. Insert a hooked tool through each screw hole in the Piston Seal Plate (4) and work the Plate upward out of the Housing.
10. Using an o-ring pick, pull the Seal Ring (5) and Piston O-ring (17) off of the Piston Rod.
11. Push the piston end of the Piston Rod forward in the Housing until the Slider Pin (14) aligns with the cross holes in the Housing.
12. Using a small drift, tap the Slider Pin out of the Sliders (5) and position shaft and remove the two Sliders.
13. Push the piston out of the Housing.
14. If the Rod Seal (16) needs replacement, use a hooked tool to pull it out of the Housing.

Disassembly of the TX-16, TX-32 and TX-45 Cylinder Assemblies

1. Grasp the Housing (1) in copper-covered or leather-covered vise jaws with the inlet end upward and using a $\frac{3}{4}$ " wrench, unscrew and remove the two Swivel Inlets (18) with their attached Couplers (19).
2. Remove the housing assembly from the vise jaws and over a container to catch the oil, move the Piston Rod Assembly (2 & 3) back and forth several times to purge the hydraulic oil from the Housing.
3. Grasp the Housing in copper-covered or leather-covered vise jaws with the inlet end upward.
4. Insert the pins of the End Plug Wrench (21) into the holes of the End Cap (7). Using a wrench on the hex of the End Plug Wrench, unscrew and remove the End Cap with the End Plug Seal (15).
5. Push the Piston Rod far enough into the Housing to expose the hex on the piston head.

NOTICE

During removal and after the piston shaft is removed; **DO NOT** grasp the round portion of the shaft with any holding device that will damage the surface. Any nicks or scratches to the surface will allow hydraulic oil to leak from the Cylinder when the tool is reassembled.

6. Using a socket on the hex of the piston head, unscrew and remove the piston head from the shaft with the Piston O-ring (17).
7. Pull the Piston shaft out of the Housing.
8. If the Sliders (5) must be replaced, position the Slider Pin (14) over a clearance opening in a soft block and use a small drift to tap the Pin out of the Sliders and shaft.
9. If the Rod Seal (16) needs replacement, use a hooked tool to pull it out of the Housing.

Disassembly of the Ratchet Link

1. Lay the Ratchet Link flat on a workbench with the Left Side Plate (1) downward and using a hex wrench, unscrew and remove the two Lower Spacer Screws (16).
2. Using a hex wrench, unscrew and remove the two Upper Spacer Screws (15).
3. For Series TX-16 and TX-32, use a roll pin punch to tap the Spacer Roll Pin (19) out of the Right Side Plate (2).
4. While applying thumb pressure to the edge of the Ratchet (6), carefully lift the Side Plate off the Assembly.
5. Grasp the Ratchet and Drive Plate (3) and, while maintaining their relationship, lift them both off the Left Side Plate.

NOTICE

In the following step, when the Ratchet is removed from the Drive Plate, the Drive Segment and Segment Spring will be free to fall from the Drive Plate recess.

Do not allow the Drive Segment to fall on a hard surface that might chip the teeth.

6. Push the Ratchet out of the Drive Plate and Remove the Drive Segment (7) and the Segment Spring (14) from the Drive Plate Recess.
7. If the Drive Pin (4) or Drive Pin Spring (5) must be replaced, use a roll pin punch to push the Drive Pin Spring Roll Pin (18) out of the Drive Plate. Once the Pin Spring is removed, the Drive Pin (4) will drop down to the large opening at the bottom of the slot for easy removal.
8. Lift the Lower Spacer (10) off the Lower Spacer Pins (11). If the Pins must be replaced, use a hex wrench to remove the two Lower Spacer Screws from the Right Side Plate. Pull the Pins out of the holes on the inner face of the Right Side Plate.
9. **For Series TX-2, TX-4, and TX-8**, unscrew the two Spacer Screws and remove the Upper Spacer (8) from the Right Side Plate. **For Series TX-16 and TX-32** use a roll pin punch to remove the Spacer Roll Pin (19) from the Right Side Plate. Unscrew the two Spacer Screws and remove the Middle Spacer (9) and Upper Spacer (8) from the Right Side Plate.
10. If the Side Plate Sleeves (12) must be replaced, press the Sleeves out toward the inner face of the Side Plate.

ASSEMBLY

General Instructions

1. Use extra care not to score, nick or damage surfaces that will contain hydraulic oil under pressure.
2. Whenever grasping a tool in a vise, always use leather-covered or copper-covered vise jaws to protect the surface of the part and help prevent distortion. This is particularly true if threaded members and housings.
3. Apply o-ring lubricant to all o-rings before final assembly.

Assembly of the Ratchet Link

1. If the Side Plate Sleeves (12) were removed, press new sleeves, shoulder end trailing, into the Right and Left Side Plates (1 & 2) from the inner face of the side Plates. Make certain the Sleeves are square with the side plate faces and the shoulder of the Sleeves enters the recesses in the Side Plates and are pressed flush with the faces.
2. **For Series TX-2, TX-4, and TX-8**, position the Upper Spacer (8) against the inside face of the Right Side Plate Apply a non-permanent thread-locking compound to the threads of the two Upper Spacer Screws (15) and secure the Spacer with the Screws through the Side Plate. **For Series TX-16 and TX-32** press the Spacer Roll Pin (19) into the Right Side Plate with one end of the Pin flush with the external face of the Side Plate. Insert the tab of the Upper Spacer (8) into the slot in the Middle Spacer (9), and after aligning the holes in both pieces, install them on the Spacer Roll Pin (19). When they are correctly positioned, apply a non-permanent thread-locking compound to the threads of the two Upper Spacer Screws (15) and secure the Spacers with the Screws through the side plate.
3. Insert the two Lower Spacer Pins (11) into the holes in the lower edge of the Right Side Plate. Apply a non-permanent thread-locking compound to the threads of the Lower Spacer Screws (16) and secure the Pins with the Screws through the Side Plate.
4. Place the Lower Spacer (10) over the Pins against the Side Plate. Make certain it is correctly oriented so that no part of the Spacer extends beyond the edge of the Side Plate.
5. Insert the Drive Pin (4) into the small cross-hole and slot in the Drive Plate (3). Invert the Plate causing the ends of the Pin to enter the slot and move the Pin to the narrow end.
6. Position the Drive Pin Spring (5) in the drive plate slot with the two non-connected ends between the Drive Pin and the large hole in the slot. Position the closed end of the Spring on the opposite side of the Pin and then apply pressure on the Spring to align the hole through it with the hole in the Drive Plate for the Drive Pin Spring Roll Pin (18). Insert the Spring Roll Pin into the Drive Plate, through the Spring and into the far wall of the Drive Plate.

NOTICE

In the following step, an excessive amount of grease will prevent proper tooth engagement between the Ratchet and the Drive Segment causing the tool to malfunction.

7. Wipe a thin film of Mobil 1 ® Synthetic Grease onto the inner race of the large opening in the Drive Plate.
8. Position the Ratchet (6) in the central opening of the Drive Plate.
9. Insert the Drive Segment (7) into the opening adjacent to the Ratchet. **Make certain the teeth of the Ratchet correctly engage the teeth of the Drive Segment.** Reverse the Ratchet if they do not properly engage.
10. Slide the Drive Segment sideways to expose the spring hole. Install the Segment Spring (14) into the hole. While compressing the Spring, slide the Drive Segment inward until the Drive Plate captures the Segment Spring.
11. Apply a light coat of Mobil 1 ® Synthetic Grease to both sides of the Drive Plate and Drive Segment. Apply some of the Mobil 1 ® Grease to the inner races of both Side Plate Sleeves (12).
12. While keeping the assembly together, insert the hub of the Ratchet into the Side Plate Sleeve of the assembled Side Plate.
13. Place the Left Side Plate Sleeve on the hub of the Ratchet and align the screw holes for the Spacers.
14. After applying a non-permanent thread-locking compound to the threads and using hex wrenches, install the two remaining Lower Spacer Screws.

Assembly of the TX-16 , TX-32 and TX-45 Cylinder Assemblies

1. Grasp the link retaining pin lug in copper-covered, vise jaws with the Housing (1) horizontal.
2. If the Rod Seal (16) was removed from the Housing, apply a coat of o-ring lubricant to the Seal and install it, lip end trailing, in the recess at the bottom of the piston bore.
3. Press the Slider Pin (14) into one of the Sliders (5) flush with one side. Install the Pin through the hole in the piston shaft and press the remaining Slider onto the Pin.
4. Install the Piston O-ring (17) in the groove of the piston head.
5. Insert the piston rod, threaded end leading, into the small central opening from the non-piston end of the Housing. The notch in the trailing end of the shaft should be toward the Ball Plunger (13).
6. Insert the piston, hex end trailing, into the bore of the Housing, and use socket to thread and tighten the piston onto the piston shaft.
7. Install the End Plug Seal (15) in the groove on the hub of the End Cap (7).
8. Using the End Plug Wrench (21), thread the assembled End Cap, o-ring end leading, into the piston end of the Housing and tighten it.

9. Wrap the threads of the Swivel Sets (18) with Teflon tape and thread the swivel with the male hose Coupler (19) into the center of the End Cap. Thread the Swivel with the female Coupler into the hole in the Housing directly above the End Cap.

Assembly of the TX-2, TX-4, and TX-8 Cylinder Assemblies

1. Grasp the link retaining pin lug in copper-covered vise jaws with the Housing (1) horizontal.
2. If the Rod Seal (16) was removed from the Housing, apply a coat of o-ring lubricant to the Seal and install it, lip end trailing, in the recess at the bottom of the piston bore.
3. Insert the piston rod, notched end leading, into the Rod Seal and the small central opening from the piston end of the Housing. The notch in the leading end of the shaft should be toward the Ball Plunger (13).
4. Push the Piston Rod (2) inward until the hole for the Slider Pin (14) aligns with the holes in the walls of the Housing.
5. Position one Slider (6) on each side of the piston shaft and insert the Slider Pin through the hole in the Housing into both Sliders and the piston shaft. The fit between the Pin and Sliders is an interference fit. Use a brass hammer and drift to set the Slider Pin below the outer edge of both Sliders or deep enough to prevent the shaft ends from dragging on the Housing walls.
6. Install the Piston O-ring (17) in the internal groove of the Seal Ring (5).
7. Install the assembled Seal Ring and Piston O-ring on the hub at the large end of the Piston Rod.
8. Install the Piston Seal Plate (4) in the inlet end of the Housing with the side having the countersunk screw holes trailing.

NOTICE

In the following step, DO NOT use thread-locking compound on the screw threads.

9. Using a hex wrench and an alternating tightening procedure, install the Retaining Screws (11). Tighten each Screw a little at a time to obtain even compression and expansion of the Piston O-ring and Seal Ring.
10. Place the Seal Insertion Tool (20) on the inlet end of the Housing.
11. Install the End Plug Seal (15) in the groove of the End Cap (7)
12. Insert the assembled End Cap into the Housing through the Tool with the O-ring end leading and the threaded inlet hole upward. Push the Cap inward beyond the Retaining Ring groove and approximately ½” into the Cylinder.
13. Remove the Seal Insertion Tool from the Housing.
14. Install the Retaining Rings (8) in the housing grooves at the inlet end of the Housing. Install the

Rings with the open ends of both rings at the middle of the opening and the beveled side of the Rings toward the End Cap.

15. If an air hose is available, inject some air into the threaded opening of the End Cap to seat the Retaining Rings. If air is not available, temporarily thread one of the Swivel Sets (18) into the threaded opening and pull the End Cap back against the Retaining Rings to seat them.
16. **For TX-2 and TX-4 models** position the End Cover (10) against the Housing and after applying a non-permanent thread-locking compound to the threads, install the End Cover Screw (12).

17. Wrap the threads of the Swivel Sets (18) with Teflon tape and thread the swivel with the male hose Coupler (19) into the threaded hole in the End Cap.
18. Apply some Mobil 1 ® Synthetic Grease to the notch in the Piston Rod and the face of the Sliders.

Assembly of the Tool

1. With the Cylinder Assembly in one hand and the Ratchet Link in the other, hook the notch on the shaft of the Piston Rod (2) onto the Drive Pin (4) and bring the two assemblies together.
2. Insert the Link Pin (9) into the hole in the Side Plate (1 or 2) until the Ball Plunger (13) snaps into the annular groove around the center of the Link Pin.

Troubleshooting Guide		
Trouble	Probable Cause	Solution
Piston will not advance or retract	Couplers are not securely attached to the tool or pump	Check the Coupler connections and make certain that they are connected.
	Coupler is defective	Replace any defective Coupler.
	Defective remote control switch	Replace the switch and/or control pendent
	Dirt in the direction-control valve of the pump unit	Disassemble the pump and clean the direction-control valve.
Piston will not retract	Hose connections reversed	Make certain the advance on the pump is connected to the advance on the tool and retract on the pump is connected to the retract on the tool.
	Retract hose not connected	Connect the retract hose securely
	Retract pin and/or Spring broken	Replace the broken pin and/or spring
Cylinder will not build up pressure	Piston Seal and/or End Plug Seal leaking	Replace any defective O-rings
	Retaining Screws sheared	Replace any broken screws.
	Coupler is defective	Replace any defective Coupler
Ratchet will not turn	Grease or dirt build up in the teeth of the Ratchet and Segment Pawl	Disassemble the Ratchet and clean the grease or dirt out of the teeth
	Worn or broken teeth on Ratchet and/or Segment Pawl	Replace any worn or damaged parts
Tool tightens immediately when turned on	Hose connections are reversed	Depress the advance button to release the tool; shut the pump off in the advance position and reverse the hose connection
Pump will not build up pressure	Defective relief valve	Inspect, adjust or replace the relief valve
	Air supply too low or air hose too small	Make certain the air supply and hose size comply with the pump manual recommendations.
	Electric power source is too low	Make certain the amperage, voltage and any extension cord size comply with the pump manual requirements
	Defective Gauge	Replace the Gauge
	Low oil level	Check and fill the pump reservoir
	Clogged filter	Inspect, clean and/or replace the pump filter
Pressure reading erratic	Defective Gauge	Replace the Gauge

NOTICE

SAVE THESE INSTRUCTIONS. DO NOT DESTROY.